

EZ10-QUAD-PY Terminal Product Description

80269ST10024a Rev. 0 - 19/09/06



Product Description

Contents

1	Overview	5
2	General Product Description.....	8
2.1	Dimensions	8
2.2	Weight.....	9
2.3	Installation.....	9
2.4	Environmental requirements.....	9
2.4.1	Temperature range	9
2.4.2	RoHS compliance	9
2.5	EZ10 Interfaces	10
2.5.1	Product Versions Identification - Documentation.....	10
2.6	Power Supply	12
2.6.1	Supply voltage requirements	12
2.6.2	Power Connector	12
2.7	General Purpose I/O	13
2.7.1	RJ11 (AUX) connector.....	13
2.7.2	GPIO Interface Specification	14
2.8	Serial Ports.....	14
2.8.1	RS232 standard interface connector	14
2.8.2	The PC as Data Terminal Equipment (DTE)	15
2.9	SIM Interface Characteristics	16
2.9.1	Insertion and Removal of the SIM	16
2.10	Antenna	18
2.10.1	Antenna Output.....	18
2.11	Operating Frequency	19
2.12	Transmitter output power	19
2.13	Reference sensitivity.....	19
2.14	User Interface.....	20
2.14.1	Switching the EZ10-QUAD-PY Terminal ON and OFF	20
2.14.2	Functions of the RJ11 Interface.....	21
2.14.3	SMS	21
2.14.4	Real Time Clock and Alarm	22
2.14.5	Data/fax transmission	22
2.14.6	Local security management.....	22
2.14.7	Call control.....	22
2.14.8	Phonebook.....	22



Product Description

80269ST10024a Rev. 0 - 19/09/06

DISCLAIMER

The information contained in this document is the proprietary information of Telit Communications S.p.A.

Telit Communications S.p.A. makes every effort to ensure the quality of the information it makes available. Notwithstanding the foregoing, Telit Communications S.p.A. does not make any warranty as to the information contained herein, and does not accept any liability for any injury, loss or damage of any kind incurred by use of, or reliance upon, the information.

Telit Communications S.p.A. disclaims any and all responsibility for the application of the devices characterized in this document and notes that the application of the device must comply with the safety standards of the applicable country and, where applicable, with the relevant wiring rules.

Telit Communications S.p.A. reserves the right to make modifications, additions and deletions to this document at any time and without notice.

© 2006 Telit Communications S.p.A.



Product Description

80269ST10024a Rev. 0 - 19/09/06

1 Overview

Aim of this document is the description of features, functions and interfaces of the **Telit EZ10-QUAD-PY Terminal** which is a complete modem solution for wireless m2m applications based on the GM862-QUAD-PY core. Since this Terminal is ready for use as a subsystem for wireless connections, Safety Information and basic instructions for taking the EZ10-QUAD-PY into operation are included, as well as guidance to other documentation and practical hints for the first steps.

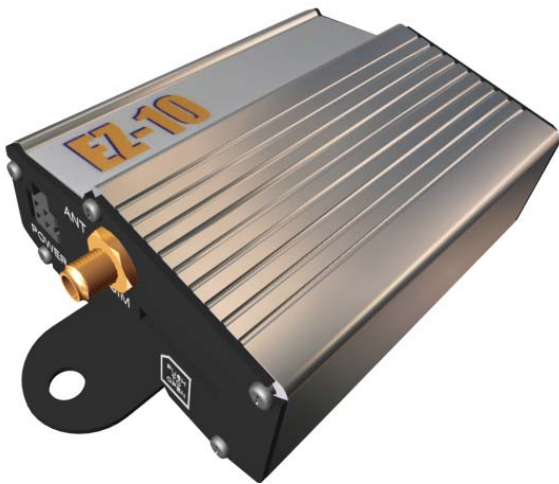

The **Telit EZ10-QUAD-PY Terminal** is GSM Mobile Stations (MS class B) capable of using the GSM Circuit Switched Data (CSD), Fax and Short Message Services (SMS).

NOTE: **Telit EZ10-QUAD-PY Terminal** is a Pb free evolution of EZ10-PCS with PYG option fully compatible with the previous model.

The frequency bands and GPRS class are reported in the following table:

Frequency Bands	GPRS	RJ11 AUX Connector	Product Name
GSM-850 / EGSM-900 / DCS-1800 / PCS-1900 MHz Quad-Band	Class 10	GPIO	Telit EZ10-QUAD-PY

The embedded **PYTHON** engine allows to perform stand-alone operations with the **EASY SCRIPT** feature, interpreting user-defined scripts in **PYTHON** language, e.g. to read external sensors connected to the General Purpose Inputs / Outputs (GPIO) on the RJ11 connector. Refer to the chapter about Software Features in this Product Description.



Product Description

80269ST10024a Rev. 0 - 19/09/06

The following table summarizes the possible interface configurations (for details refer to the dedicated chapters of this document):

	EZ10-QUAD-PY (GPIO & PYTHON)
RS232 Serial Interface for AT commands, data, fax, SMS	YES
POWER 12V DC	YES
AUX RJ11 6-pin configuration	GPIO: GND GPIO 4, GPIO 6 / Alarm GPIO 7 / Buzzer GPIO 5 Vmod (3,8 V DC) Remarks: <ul style="list-style-type: none"> • Automatic POWER ON. • GPIOs can be configured as I²C or SPI bus by PYTHON script elements.

The EZ10-QUAD-PY allows to be remotely controlled by AT commands (GSM 07.07 and 07.05) and the connection to the host controller (Data Terminal Equipment DTE) is established through one RS232 standard port. This port serves also for serial bi-directional Data and Fax transfer.

All the interfacing is done by 4 connectors placed on the front and rear panels.

The Quad-band evolution **Telit EZ10-QUAD-PY** includes features like sensing of hot removal of the SIM, the higher upload speed of the GPRS Class 10 Packet Data transfer and the entire structure results in a RoHS compliant product.

EASY GPRS® Embedded

Telit EZ10-QUAD-PY embeds TCP/IP stack and DNS query protocol. Static and dynamic IP allocation, PPP and UDP as well as FTP Client are supported. Developers just need to add Telit Proprietary AT commands to establish a TCP/IP connection through the GPRS network.

EASY FREQUENCY SCAN® Function

Telit EZ10-QUAD-PY includes a dedicated set of AT commands to scan all the GSM channels, reporting all available parameters. With EASY FREQUENCY SCAN® the GSM network coverage at the location of the EZ10-QUAD-PY Terminal can be examined even without inserted SIM in order to select the provider with the best field strength, the most channels or base transceiver stations and to optimize the antenna position.

EASY SCRIPT® Function

Telit EZ10-QUAD-PY includes a dedicated set of AT commands to run scripts in **PYTHON**¹ language within the module. By using this EASY SCRIPT® feature, the script inside the module interacts with

¹ PYTHON is a registered trademark of the Python Software Foundation.



EZ10-QUAD-PY Terminal

Product Description

80269ST10024a Rev. 0 - 19/09/06

the interfaces, allowing other tasks to interrupt it. The script interpreter engine of **Telit EZ10-QUAD-PY** is allowing self controlled operations.

With the **Telit EZ10-QUAD-PY** it is possible to configure the available GPIOs 4-7 as I²C or SPI bus.

JAMMING DETECTION and REPORT

The **Telit EZ10-QUAD-PY** offers the Jamming Detection and Report functionality, which allows the unit to detect attempts to discontinue GSM communication by interfering with the GSM radio signal. The “Jammed” status is reported as unsolicited message through the AT-Command interface on the RS232 connection.

The EZ10-QUAD-PY is compliant with the relevant parts of ETSI GSM Phase 2+ specifications (Normal MS). Furthermore, **Telit EZ10-QUAD-PY** is certified after the full conformity assessment against 1995/5 EC and R&TTE Directive and they don't require any further certification test effort and expense. The Terminal EZ10 can be used in all EU countries and in other countries where a GSM-850/E-GSM-900/DCS-1800MHz or PCS 1900 MHz network is available.

It is necessary to insert a **SIM** (Subscriber Identity Module, type 3 Volt Plug-in) on which the level of worldwide access to the services of the related GSM/GPRS network depends.



Product Description

80269ST10024a Rev. 0 - 19/09/06

2 General Product Description

NOTE: The illustrations in this Product Description are only schematic and do not assure fidelity to construction or layout details, finishes, writings or colours.

2.1 Dimensions

The **Telit EZ10-QUAD-PY** dimensions are:

- **Housing Length:** 83 mm (without connectors)
- **Overall Length:** 107 mm (including fixtures)
- **Width:** 64 mm
- **Thickness:** 33 mm

See the following figure:

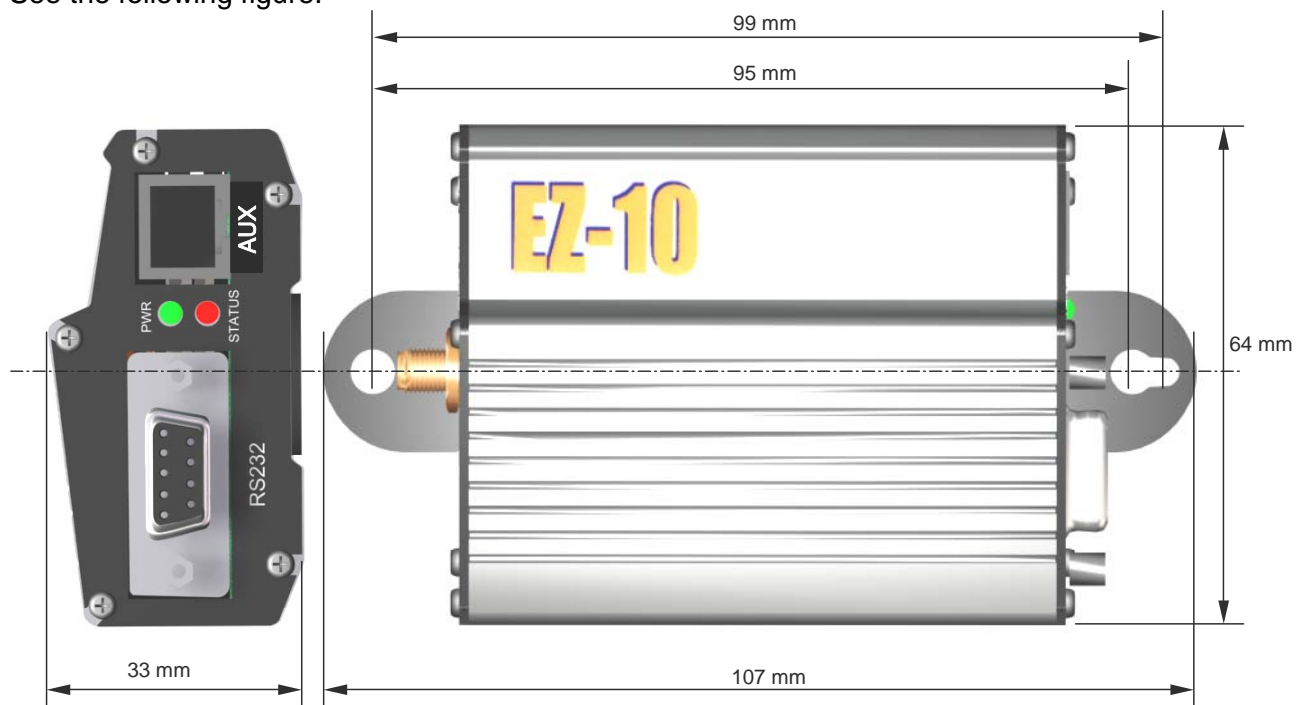

Product Description

80269ST10024a Rev. 0 - 19/09/06

2.2 Weight

The net weight of the **Telit EZ10-QUAD-PY** is **150 grams**.

2.3 Installation

The **Telit EZ10-QUAD-PY** can be fixed on a suitable surface by two screws through the holes (3,3 / 5,8 mm diam.) in the lids forming part of the front and rear panels. The figure shows the maximum and minimum inter-axis distance between the fixing holes.

In case of a permanent vertical installation in dusty environment, it is recommended to cover the SIM slot with a self-adhesive tape.

2.4 Environmental requirements

The **Telit EZ10-QUAD-PY** is compliant with the applicable ETSI reference documentation GSM 05.05 Release1999 ETSI EN300910 V8.4.1

2.4.1 Temperature range

- Temperature in normal functional conditions $-10^{\circ}\text{C} \div +55^{\circ}\text{C}$
- Temperature in extreme functional conditions* $-20^{\circ}\text{C} \div +70^{\circ}\text{C}$
- Temperature in storage conditions $-30^{\circ}\text{C} \div +85^{\circ}\text{C}$

Temperature exceeding the range of normal functional conditions can affect the sensitivity and performance of the modem.

2.4.2 RoHS compliance

The **EZ10-QUAD-PY** is fully RoHS compliant to EU regulation.



EZ10-QUAD-PY Terminal Product Description

80269ST10024a Rev. 0 - 19/09/06

2.5 EZ10 Interfaces

The interfaces of the **EZ10-QUAD-PY Terminal** are distributed on 4 connectors on the front and rear panels, see figure.

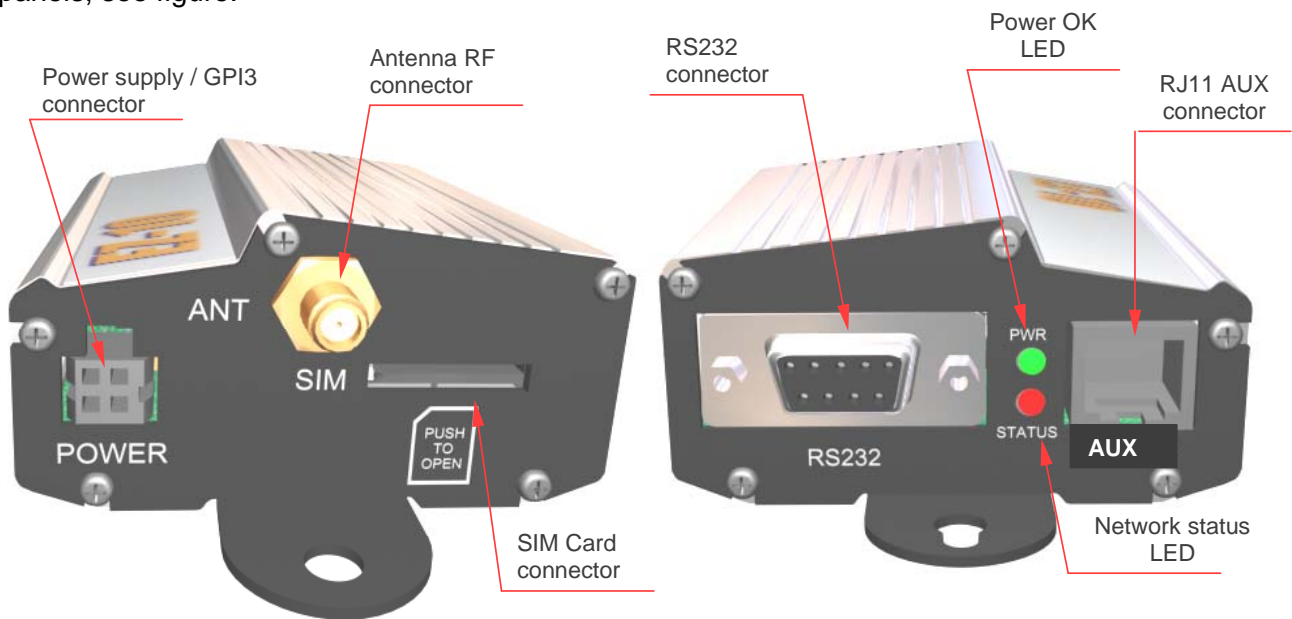

2.5.1 Product Versions Identification - Documentation

2.5.1.1 Hardware Identification



EZ10-QUAD-PY Terminal

Product Description

80269ST10024a Rev. 0 - 19/09/06

Each Terminal has a **Serial Number** on the TYPE label, by which the **IMEI** of the **Telit module Engine** inside can be retrieved from a production database at the manufacturer. In addition, the IMEI can be obtained in functional conditions with a Data Terminal Equipment (DTE) as response to a specific AT-command: AT+CGSN, AT#CGSN.

The following accessories for the EZ10-QUAD-PY can be made available separately:

Article	Telit Part No.
GSM Quad-Band Antenna 2.5dBi gain, magnetic surface mount with ca. 2,5 m coaxial cable RG174 and SMA m connector;	1rr0100056tlb
RS232 data cable, ca. 1,8m SubD9 m-f, straight	1ff1400065ezr
AC adapter: Input 100-240V AC 50..60Hz, Euro Plug Output 12V DC 1,2 A, ca. 1,8m cable with 4-pin plug (Molex 43025-400), GPIO3 bridged to GND at plug	1jj0400034ezr
AC adapter: Input 100-240V AC, 50..60Hz, UK Plug Output 12V DC 1,2 A, ca. 1,8m cable with 4-pin plug (Molex 43025-400), GPIO3 bridged to GND at plug	1jj0400035ezr
AC adapter: Input 100-240V AC, 50..60Hz, US Plug Output 12V DC 1,2 A, ca. 1,8m cable with 4-pin plug (Molex 43025-400), GPIO3 bridged to GND at plug	1jj0400036ezr

NOTE: Specifications and Part Numbers are subject to modifications.

2.5.1.2 Software identification

The version of the Software (SW) (firmware) implemented in production (on the Telit Cellular Engine inside) can be read from the SW label. In addition, the SW version can be obtained in functional conditions with a Data Terminal Equipment (DTE) as response to a specific AT-command: AT+CGMR. This is especially useful when the SW has been updated after delivery.

2.5.1.3 Documentation and User Guides

The description of the **AT Commands** that are implemented in the EZ10-QUAD-PY is available on www.telit.com >Products >Modules >GM862-QUAD-PY² as a separate document: “**AT Commands Reference Guide**”.

The **Software Features** are described in a dedicated chapter of this Product Description.

Practical examples for the use of AT commands and some applications can be found in the **GM862-QUAD-PY Software User Guide** available on the same location on www.telit.com

² In all additional documentation please refer always to the product GM862-QUAD-PY with the following Order-No. 3990250656 since this is the core engine inside of EZ10-QUAD-PY



EZ10-QUAD-PY Terminal

Product Description

80269ST10024a Rev. 0 - 19/09/06

Technical information and reference designs for external circuitry partially relevant for the EZ10-QUAD-PY can be found in the **GM862 Hardware User Guide** available on www.telit.com >Products > GM862-QUAD-PY

2.6 Power Supply

2.6.1 Supply voltage requirements

The DC power supply must be connected to the POWER input:

- Input voltage range: 12 - 24V DC
- Nominal Voltage: 12V DC

NOTE: these are the absolute maximum ratings – for use e.g. in trucks with 24V nominal voltage, an additional DC/DC converter has to be used.

- Power Supply current rating: min. 1,2A @12V
- Power Supply ripple: max. 120mV
- Input current in idle mode: 8mA @ 12V
- Input average current in communication mode: 110mA @ 12V

NOTE: In case that power supply equipment is to be ordered, its conformity needs to be verified with the mains supply voltage, frequency, connector type and other national requirements (e.g. certifications) in the countries of its use.

2.6.2 Power Connector

The power connector is on the left side of the terminal is Molex 4-pin connector (part no.:43045-0400 male)

Pin description:

- GND = Ground reference (1x POWER, 1x Signal)
- Input Power = 12 - 24VDC
- GPIO3 input CMOS 2.8 (voltage range allowed on this pin: 0-3,6VDC vs. GND)

FRONT VIEW

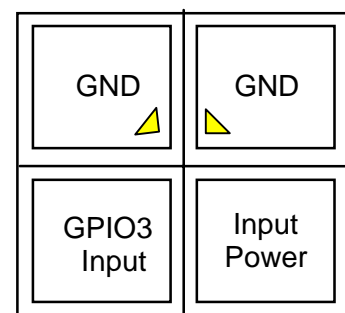

Product Description

80269ST10024a Rev. 0 - 19/09/06

2.7 General Purpose I/O

2.7.1 RJ11 (AUX) connector

The signals on the RJ11 connector has 4 digital general purpose inputs/outputs (GPIO). Connector type on the terminal is:

- Molex RJ11/6pin, part no.:95001-2661

The voltage range allowed on each pin is 0-3,6V DC. AUTO POWER ON is enabled.

VMOD = direct connection to the pin of the power supply voltage input of the Telit module (3.8V typical) and the output of the internal switching voltage regulator. The presence of this line at pin6 is to be considered as a low power output (<30mA) for pull-up potential (requires external reduction of voltage to max. 3,6V DC!).

NOTE: Connections to VMOD shall be made only when familiar with designing circuits conform to EMC requirements.

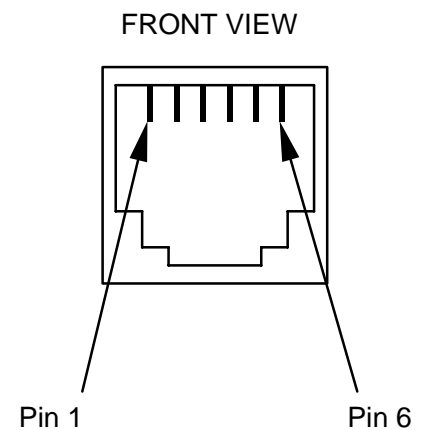

All General Purpose input / output lines on the RJ11 GPIO interface have a 100 pF bypass capacitor to ground and are connected to the related pins of the Telit module over a 100 Ohms series resistor.

pin	Signal	I/O	Function	Internal Pull UP	Type
1	GND	-	Power Ground (negative)/ Signal Ground		POWER/GND
2	GPIO4	I/O	Configurable general purpose I/O pin /		CMOS 2.8V
3	GPIO6 / ALARM	I/O	Configurable general purpose I/O pin / ALARM		CMOS 2.8V
4	GPIO7 / BUZZER	I/O	Configurable general purpose I/O pin / BUZZER		CMOS 2.8V
5	GPIO5	I/O	Configurable general purpose I/O pin		CMOS 2.8V
6	VMOD	O	Low power supply output (typically +3.8V DC)		POWER OUT



Product Description

80269ST10024a Rev. 0 - 19/09/06

2.7.2 GPIO Interface Specification

Where not specifically stated, all the interface circuits work at 2.62V CMOS logic levels.

All General Purpose input / output lines on the RJ11 GPIO interface have a 100 pF bypass capacitor to ground and are connected to the related pins of the Telit module over a 100 Ohms series resistor.

The following table shows the logic level specifications in the Telit EZ10-QUAD-PY terminal interface circuits:

LEVEL	MIN	MAX
Input high level	2.1 V	3.6V
Input low level	0 V	0.5 V
Output high level	2.2 V	3.0 V
Output low level	0 V	0.35 V

See the GM862-QUAD-PY HW and SW User Guides for

- Examples how to use the GPIO, e.g. setting over the air, sensing (polling) over the air or locally by the DTE,
- Configuration as ALARM output or BUZZER,
- Example input circuit (e.g. to detect a 12-V signal or a passive contact),
- Example output circuit (e.g. to drive a Relay in 12-V-environment or to connect a LED).

2.8 Serial Ports

The RS232 standard interface serves to connect a PC, Data Terminal Equipment (DTE) or an application, which acts as host controller of the EZ10-QUAD-PY Terminal with all its functions. Through the RS232 interface it can be used as GSM/GPRS modem for sending and receiving of SMS, Data and Fax calls.

The **Telit EZ10-QUAD-PY**, on the basis of the **EASY SCRIPT®** feature and with a **PYTHON** script developed by the user, can allow self-controlled operations which put the RS232 interface in a different serial data transmission mode, e.g. to communicate with a sensor or actuator.

2.8.1 RS232 standard interface connector

Connector type on the terminal:



EZ10-QUAD-PY Terminal

Product Description

80269ST10024a Rev. 0 - 19/09/06

- RS-232 through D9-pin female
- Baud rate from 300 to 115.200 bit/s
- Autobauding (300 to 38.400 bit/s)
- Short circuit (to Ground) protection on all outputs.

The EZ10-QUAD-PY provides low-pass RF suppression circuits and level conversion to the Engine inside.

Input voltage range: -12V to +12V

Pin out (refers to DTE side):

- Pin 1 = DCD Output
- Pin 2 = RX Output
- Pin 3 = TX Input
- Pin 4 = DTR Input
- Pin 5 = Ground
- Pin 6 = DSR Output
- Pin 7 = RTS Input
- Pin 8 = CTS Output
- Pin 9 = RI Output

To connect to a PC as DTE, a pin-to-pin, 9 pin cable with D9 type connectors on both sides is needed (1 male & 1 female). Shielding of this cable is recommended and its length shall not exceed 3m.

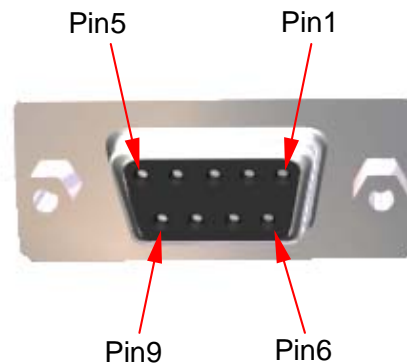

2.8.2 The PC as Data Terminal Equipment (DTE)

The software application for using the PC RS232 standard serial interface (COM-port) as Data Terminal Equipment (DTE) is usually Hyper Terminal. Connect using the COM-port to which the EZ10-QUAD-PY Terminal is connected with the following settings:



EZ10-QUAD-PY Terminal Product Description

80269ST10024a Rev. 0 - 19/09/06

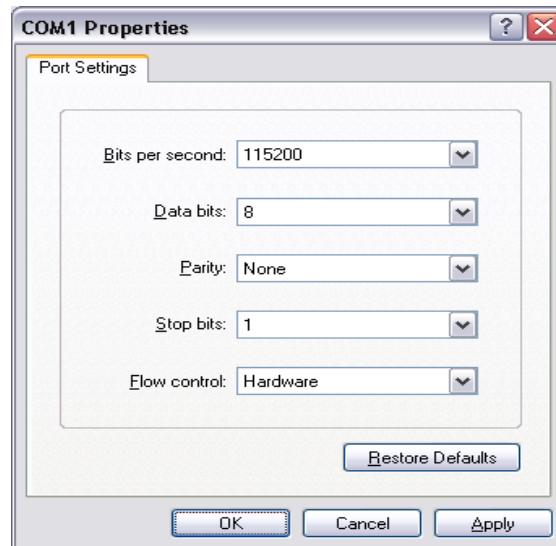

For more information about which AT Commands are implemented on the EZ10-QUAD-PY Terminal can be found in the “GM862-QUAD-PY Software User Guide” and “AT Commands Reference Guide”, available on www.telit.com - >Products >Modules > GM862-QUAD-PY >Download.

2.9 SIM Interface Characteristics

The **Telit EZ10-QUAD-PY** support plug-in type Subscriber Identity Modules (SIM) according to GSM11.14 Phase 2 – with 3 Volts supply ONLY.

For the technical characteristics of the SIM, refer to the documentation supplied together with the SIM by the Mobile Network Operator or Service Provider.

The **Telit EZ10-QUAD-PY** has an enhanced SIM card reader with a sensor that allows detecting of a “hot” removal of the SIM, therefore the SIM can be extracted and re-inserted while the module is still on.

NOTE: On the **Telit EZ10-QUAD-PY** the sensing of a hot removal of the SIM is not supported during power saving mode (AT+CFUN=5).

2.9.1 Insertion and Removal of the SIM

The terminal has a built-in toggle spring (Push-Push) SIM holder, accessible through a slot in the panel at the antenna side of the housing.

Do not insert or remove the SIM when the product is in power saving mode.



EZ10-QUAD-PY Terminal

Product Description

80269ST10024a Rev. 0 - 19/09/06

To insert and remove the SIM, a plastic strip of the same width of the SIM and appropriate length of ca. 50-100 mm shall be prepared as a tool. The figure printed on the panel shows the position of the cut edge and the direction, how the SIM shall be inserted.

Insert the SIM and push it with the tool slightly inside until the spring snaps in. Removing the tool, the SIM shall remain inside the EZ10-QUAD-PY. For removing the SIM, push the tool slightly inside until the spring is released so that it pushes the SIM outside when the tool is retracted.



Product Description

2.10 Antenna

2.10.1 Antenna Output

NOTE: BEFORE connecting the EZ10-QUAD-PY to a Power Supply source, a suitable Antenna shall be connected and properly installed.

As accessory, a magnetic surface mount antenna with 2.5dBi gain, ca. 2.5 m of coaxial cable and SMA connector is available.

The antenna has to be installed with care in order to avoid any interference with other electronic devices and has to guarantee a minimum distance from persons (20 cm). In case this requirement cannot be satisfied, the system integrator has to assess the final product against the SAR regulation. For a good efficiency of the antenna and minimum interference with other electronic systems, a space of min. 40 cm around the radiating part should be free, at least of electrically conducting materials (except the ground plane on which it is attached).

Less distance and less obstacles there are between the antenna connected to the EZ10-QUAD-PY Terminal and the antenna of the GSM/GPRS network base station, the less power is radiated by the Terminal under normal conditions and the higher is the safety margin in case of disturbances.

A check of eventual interferences can be made when the EZ10-QUAD-PY Terminal transmits at maximum power level to register to a GSM 900 network (see frequency channel numbers), immediately after being switched on.

2.10.1.1 Antenna Connector

The **Telit EZ10-QUAD-PY** includes a SMA bulkhead female, class 4 (2W) co-axial connector for the external antenna.

2.10.1.2 Antenna Specification

The antenna to be connected shall fulfil the following requirements:

Frequency range	Standard Dual Band GSM/DCS frequency range or Standard Quad Band GSM/DCS/PCS frequency range if used for all four bands
Bandwidth	80 MHz in EGSM 900, 70 MHz if GSM 850, 170 MHz in DCS, 140 MHz PCS band
Gain	1.5dBi ≤ Gain < 3dBi (referenced to isotropic radiator)
Impedance	50 Ohm
Input power	> 2 W peak power



Product Description

2.14 User Interface

The user interface of the EZ10-QUAD-PY Terminal is accessible from a Data Terminal Equipment DTE connected to the RS232 interface and it is managed by AT commands according to the GSM 07.07 and 07.05 specification and the supported commands are listed in the *AT Commands Reference Guide*.

2.14.1 Switching the EZ10-QUAD-PY Terminal ON and OFF

In this paragraph will be explained the way to switch the EZ10-QUAD-PY Terminals ON or OFF.

NOTE: Switching OFF the EZ10-QUAD-PY by disconnecting the external power supply line requires to wait enough time that the load capacitor of the DC/DC converter inside the EZ10-QUAD-PY discharges so that the Telit module inside goes to OFF condition.

- The EZ10-QUAD-PY Terminal switches on automatically each time the Power Supply is connected the first time or re-connected.
- The EZ10-QUAD-PY Terminal can be turned OFF by the command AT#SHDN, but immediately thereafter it switches ON again automatically (AUTO POWER ON always enabled).

2.14.1.1 GSM/GPRS Standard Modem

It is always worth a trial to install the EZ10-QUAD-PY Terminal as modem on a PC in the following way:

First add it in the PC's Control Panel – Telephone and Modem. Select from the list the “Standard 33600 bps Modem” with connection to the related COM port, then make a new “Dial-up connection to private network” using this modem with the dial-up parameters of the GSM/GPRS Network in use. Sometimes the parameters indicated for the use of the WAP-Browser of mobile phones (over GSM CSD call or GPRS) will work.

Example for a GPRS connection set-up:

Under “Properties-General Configure” the initialization has to be entered in the text box selecting “Run Script”. The parameters are examples for subscribers of Italian GSM network operators.

Initialization: AT+CGDCONT=1,"IP","web.omnitel.it"

Dial number : *99***1#

User Name : none

Password : none

Initialization: AT+CGDCONT=1,"IP","internet.wind.biz"



Product Description

80269ST10024a Rev. 0 - 19/09/06

2.14.4 Real Time Clock and Alarm

The **Telit EZ10-QUAD-PY** supports the Real Time Clock and Alarm functions through the AT command interface.

Furthermore, an alarm output pin (GPIO6) can be configured to indicate the alarm with a hardware line output.

2.14.5 Data/fax transmission

The **Telit EZ10-QUAD-PY** supports:

- Packet Data transfer GPRS Class B, Multi-slot Class 8.
- Packet Data transfer GPRS Class B, Multi-slot Class 10.
- Data transmission according to the GSM 07.07, 07.05
- CSD up to 14.4 Kbps
- Fax service, Class 1 Group 3

2.14.6 Local security management

With lock of Subscriber Identity module (SIM), and security code request at power-up.

2.14.7 Call control

Call cost control function.

2.14.8 Phonebook

Function available to store the telephone numbers in SIM memory.
Capability depends on SIM version/memory

2.14.9 Characters management

Availability of lowercase, uppercase and IRA characters (International Reference Alphabet), in TEXT and PDU mode.

2.14.10 SIM related functions

Activation/deactivation of the numbers stored in phone book FDN, ADN and PINs. Extension at the PIN2 for the PUK2 insertion capability for lock condition.

Do not insert or remove the SIM when the product is in power saving mode.

NOTE: The SIM (Subscriber Identity Module) from the Network Operator or Service Provider can be configured in different ways, e.g. related to



Product Description

80269ST10024a Rev. 0 - 19/09/06

- The presence of SIM Applications (not supported by the current Software of EZ10-QUAD-PY Terminal),
- The possibility to de-activate the necessity to enter the PIN (Personal Identification Number) as condition for registering in the network;
- The possibility that the Terminal can be locked by factory SW settings to a certain SIM of a certain Network Operator.
- The presence and format of certain phone book directories (PB, FDN, ADN) or SMS memories.
- The presence, content and format of other registers in the SIM, e.g. network operator's name, list of preferred networks (names change from time to time), etc.
- The possibility to roam between several mobile networks even in the home country.

2.14.11 Call status indication

The call status indication by AT commands and Status LED is supported.

2.14.12 LED Indicators

The EZ10-QUAD-PY Terminal has 2 LED indicators, one for Power, one for Status.

2.14.12.1 Power LED

When on, the green Power LED indicates that the supply voltage is arriving at the GSM Engine inside the EZ10-QUAD-PY Terminal.

2.14.12.2 Status LED: Indication of network service availability

The red Status LED is connected internally to the STAT_LED output of the module by an inverting circuit. In addition to the status information obtainable via AT commands, this LED shows information on the network service availability and Call status.

Status LED indications

LED status	Device Status
permanently on	device off
fast interrupt sequence (period 0,5s, Ton 1s)	Net search / Not registered / turning off
slow interrupt sequence (period 0,3s, Ton 3s)	Registered full service
permanently off	a call is active



Product Description

80269ST10024a Rev. 0 - 19/09/06

2.14.13 Automatic answer (Data or FAX)

After a specified number of rings, the module will automatically answer with a beep. The user can set the number of rings by means of the command `ATS0=<n>`.

2.14.14 Supplementary services (SS)

- Call Barring,
- Call Forwarding,
- Calling Line Identification Presentation (CLIP),
- Calling Line Identification Restriction (CLIR),
- Call Waiting, other party call Waiting Indication,
- Closed User Group supplementary service (CUG),
- Advice of Charge,
- Unstructured SS Mobile Originated (MO)



Product Description

80269ST10024a Rev. 0 - 19/09/06

3 Software Features

3.1 Enhanced EASY GPRS Extension

3.1.1 Overview

The EASY GPRS feature allows a user of the **Telit EZ10-QUAD-PY** to contact a device in the Internet and establish with it a raw data flow over the GPRS and Internet networks.

This feature can be seen as a way to obtain a "virtual" serial connection between the Application Software on the Internet machine involved and the controller of the **Telit EZ10-QUAD-PY**, regardless of all the software stacks underlying.

An example of the protocol stack involved in the devices is reported:

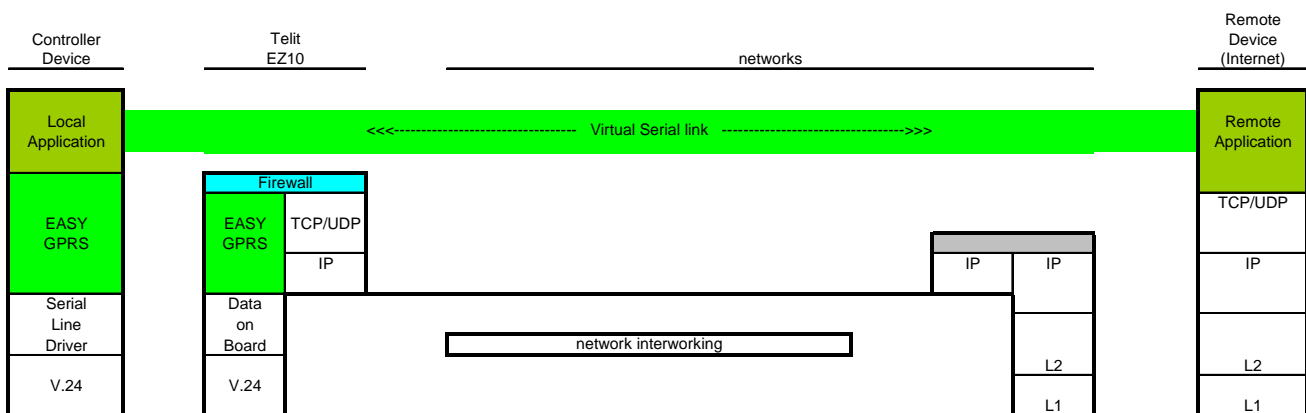

This particular implementation allows to the devices interfacing to the **Telit EZ10-QUAD-PY** the use of the GPRS and Internet packet service without the need to have an internal TCP/IP stack since this function is embedded inside the module.

The new **Enhanced version** of the EASY GPRS overcomes some of the known limitations of the previous implementation and implements some new features such as:

- Keep the GPRS context active even after the closing of a socket, allowing the application to keep the same IP address;
- Also Mobile terminated (incoming) connections can be made, now it is possible to receive incoming TCP connection requests;



EZ10-QUAD-PY Terminal

Product Description

80269ST10024a Rev. 0 - 19/09/06

- A new internal firewall has been implemented in order to guarantee a certain level of security on internet applications.



EZ10-QUAD-PY Terminal

Product Description

80269ST10024a Rev. 0 - 19/09/06

This command permits also to specify the host name instead of its IP address, if a host name is given to the set command, then the module stores it as a host nick name. It is care of the module user to guarantee that the host nick name provided corresponds to an existing internet peer.

If a host nick name has been given then, while opening the connection in response to the AT#SKTOP command, the module will autonomously activate a GPRS connection and query its DNS to obtain the IP address relative to the host nick name provided. This process of context activation and DNS query may require a bit more time and requires that the GPRS network coverage is good enough to permit data transfers.

3.1.2.4 Open the connection with the internet host

With the AT#SKTOP all the process required to connect with the internet host starts:

- EZ10-QUAD-PY activates the first context
- EZ10-QUAD-PY proceeds to the authentication
- Eventually does the DNS query to resolve the IP address of the host name internet peer
- EZ10-QUAD-PY establishes a TCP/UDP (depending on the parameter request) connection with the given internet host
- Once the connection is up the module reports the code: CONNECT

From this moment the data incoming in the serial port is packet and sent to the Internet host, while the data received from the host is serialized and flushed to the Terminal Equipment.

3.1.2.5 Close the Socket and deactivate the context

The connection can be closed because of:

- remote host TCP connection close
- socket inactivity timeout
- Terminal Equipment by issuing the escape sequence "+++"
- Network deactivation

NOTE: if in the raw data to be sent there's an escape sequence, then the TE must work it out and sent it in a different fashion to guarantee that the connection is not closed.

The pause time is defined in the parameter S12.

On the reception of an escape sequence the EZ10-QUAD-PY closes the connection, deactivates the GPRS context returning to command mode and issuing the NO CARRIER code.

3.1.3 Enhanced EASY GPRS Outgoing connection

The New Enhanced EASY GPRS feature provides a way to place outgoing TCP/UDP connections and keep the same IP address after a connection, leaving the GPRS context active.

The steps that will be required open a socket and close it without closing the GRPS context are:

- configuring the GPRS Access
- configuring the embedded TCP/IP stack behaviour
- defining the Internet Peer to be contacted



Product Description

80269ST10024a Rev. 0 - 19/09/06

3.1.3.4 Request the GPRS context to be activated

With the new command #GPRS you can activate or deactivate a GPRS context INDEPENDENTLY from the TCP socket opening,
 AT#GPRS=1 activates the context,
 AT#GPRS=0 deactivates the context

Therefore with the AT#GPRS=1 command the module

- EZ10-QUAD-PY activates the context previously defined with AT+CGDCONT
- EZ10-QUAD-PY proceeds to the authentication
- Note that activating a context implies getting an IP address from the network and this will be maintained throughout the session.

The response code to the AT#GPRS=1 command reports the IP address obtained from the network, allowing the user to report it to his server or application.

Deactivating the context implies freeing the network resources previously allocated to the device.

3.1.3.5 Open the Connection with the Internet Host

With the new command #SKTD (socket Dial) the TCP/UDP request to connect with the internet host starts:

- Eventually does the DNS query to resolve the IP address of the host name internet peer
- EZ10-QUAD-PY establishes a TCP/UDP (depending on the parameter request) connection with the given internet host
- Once the connection is up the module reports the code: CONNECT

Note that the peer specifications of this socket Dial are within the command and not the one stored with #SKTSET command.

From this moment the data incoming in the serial port is packet and sent to the Internet host, while the data received from the host is serialized and flushed to the Terminal Equipment.

NOTE: this command differently from the AT#SKTOP DOES NOT automate all the process of activating the GPRS, if no GPRS is active the command reports ERROR; therefore before issuing this command the GPRS shall be activated with AT#GPRS=1 command.

In the same manner, when disconnecting the #SKTD command does not close the GPRS context, leaving it active for next connections until an AT#GPRS=0 command is issued or the network requests a context closing.

3.1.3.6 Close the Socket without deactivating the context

The connection can be closed because of:

- remote host TCP connection close
- socket inactivity timeout
- Terminal Equipment by issuing the escape sequence "+++"
- Network deactivation



Product Description

80269ST10024a Rev. 0 - 19/09/06

When packet incomes from the IP address <incoming IP>, the firewall chain rules will be scanned for matching with the following criteria:

<incoming IP> & <net mask> = <ip_address> ?

if the result is yes, then the packet is accepted and the rule scan is finished, otherwise the next chain is taken into account until the end of the rules when the packet is silently dropped if no matching was found.

For example, let assume we want to accept connections only from our devices which are on the IP addresses ranging from:

197.158.1.1 to 197.158.255.255

We need to add the following chain to the firewall:

AT#FRWL=1,"197.158.1.1","255.255.0.0"

3.1.4.2 Request the socket connection to be opened in listen

With the new command #SKTL (socket Listen) the TCP request to start listening for connection requests is executed:

- EZ10-QUAD-PY opens a listening socket on the port specified, waiting for incoming TCP connections (depending on the parameter request) with the internet hosts

The parameters that shall be specified are the local port where packets shall be received, the type of socket and the closing behaviour.

3.1.4.3 Receiving connection requests

Once the connection request is received, the module reports an indication of connection with an unsolicited code

+CONN FROM: <remote address>

- then connection is accepted and once it is up the module reports the code:

CONNECT

From this moment the data incoming in the serial port is packet and sent to the Internet host, while the data received from the host is serialized and flushed to the Terminal Equipment.

Note that the connections request are FIRST screened in the firewall, then if they are accepted they pass to the listening socket; therefore only hosts that are in the ACCEPT chain rules of the firewall can induce a connection request, the other host requests will be silently discarded without any indication to the remote host (for security reasons).

Once the connection is received and closed, the socket is not anymore in listen. If the application needs again to be in listen, then it shall send again the socket listen #SKTL command.



Product Description

80269ST10024a Rev. 0 - 19/09/06

3.2 Jammed Detect & Report Extension

3.2.1 Overview

The Jammed Detect & Report feature allows a **Telit EZ10-QUAD-PY** to detect the presence of a disturbing device such as a Communication Jammer and give indication to the user and/or send a report of that to the network.

This feature can be very important in alarm, security and safety applications that rely on the module for the communications. In these applications, the presence of a Jammer device can compromise the whole system reliability and functionality and therefore shall be recognized and reported either to the local system for countermeasure actions or to the network providing remote actions.

An example scenario could be an intrusion detection system that uses the module for sending the alarm indication for example with an SMS to the system owner, and thief incomes using a Jammer to prevent any communication between the GSM module and the network.

In such a case, the module detects the Jammer presence even before the break-in and the host controller can trigger an alarm siren, other communication devices (PSTN modem) or directly report this condition to the network that can provide further security services for example sending SMS to the owner or police. Obviously this last service depends also from network infrastructure support and it may not be supported by some networks.



Product Description

80269ST10024a Rev. 0 - 19/09/06

3.3 Easy Script Extension - Python interpreter

NOTE: Embedding the PYTHON GSM/GPRS Engine into the **Telit EZ10-QUAD-PY**, the second serial interface is not accessible from outside. The only general purpose input output ports usable are the GPI3, GPIO4, 5, 6 and 7. This implicates restrictions on the creation of I²C and SPI busses. Of course, all scripts taking care of these restrictions can be run on **Telit EZ10-QUAD-PY**, whereas for script development, the Python Kit or EVK are recommended because of their extra interfaces for debugging the script software.

3.3.1 Overview

The Easy Script Extension is a feature that allows driving the modem "internally", writing the controlling application directly in a nice high level language: Python.

The Easy Script Extension is aimed at low complexity applications where the application was usually done by a small microcontroller that managed some I/O pins and the EZ10-QUAD-PY through the AT command interface.

A schematic of such a configuration can be:

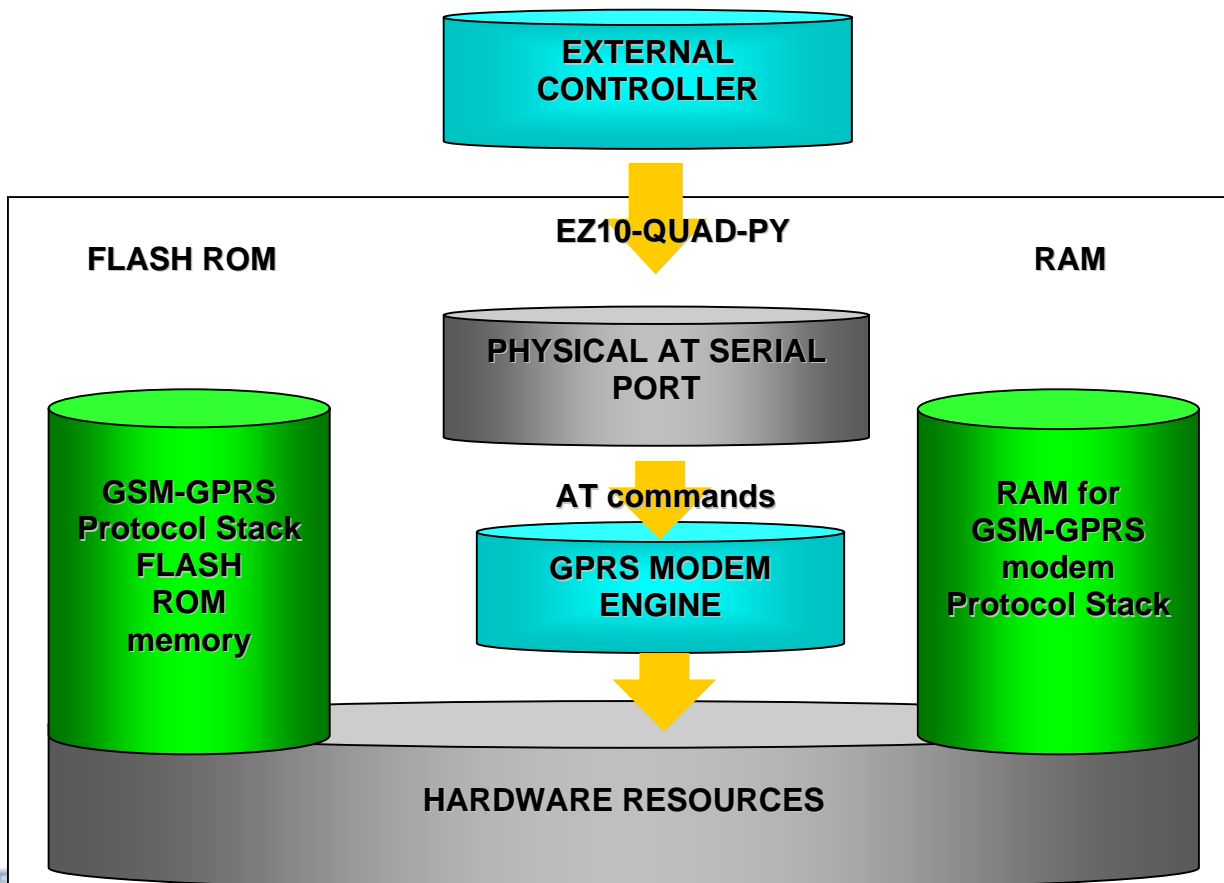

EZ10-QUAD-PY Terminal Product Description

80269ST10024a Rev. 0 - 19/09/06

In order to eliminate this external controller, and further simplify the programming of the sequence of operations, inside the EZ10-QUAD-PY it is included:

- Python script interpreter engine v. 1.5.2+
- around 3MB of Non Volatile Memory room for the user scripts and data
- 1.5 MB RAM reserved for Python engine usage

A schematic of this approach is:

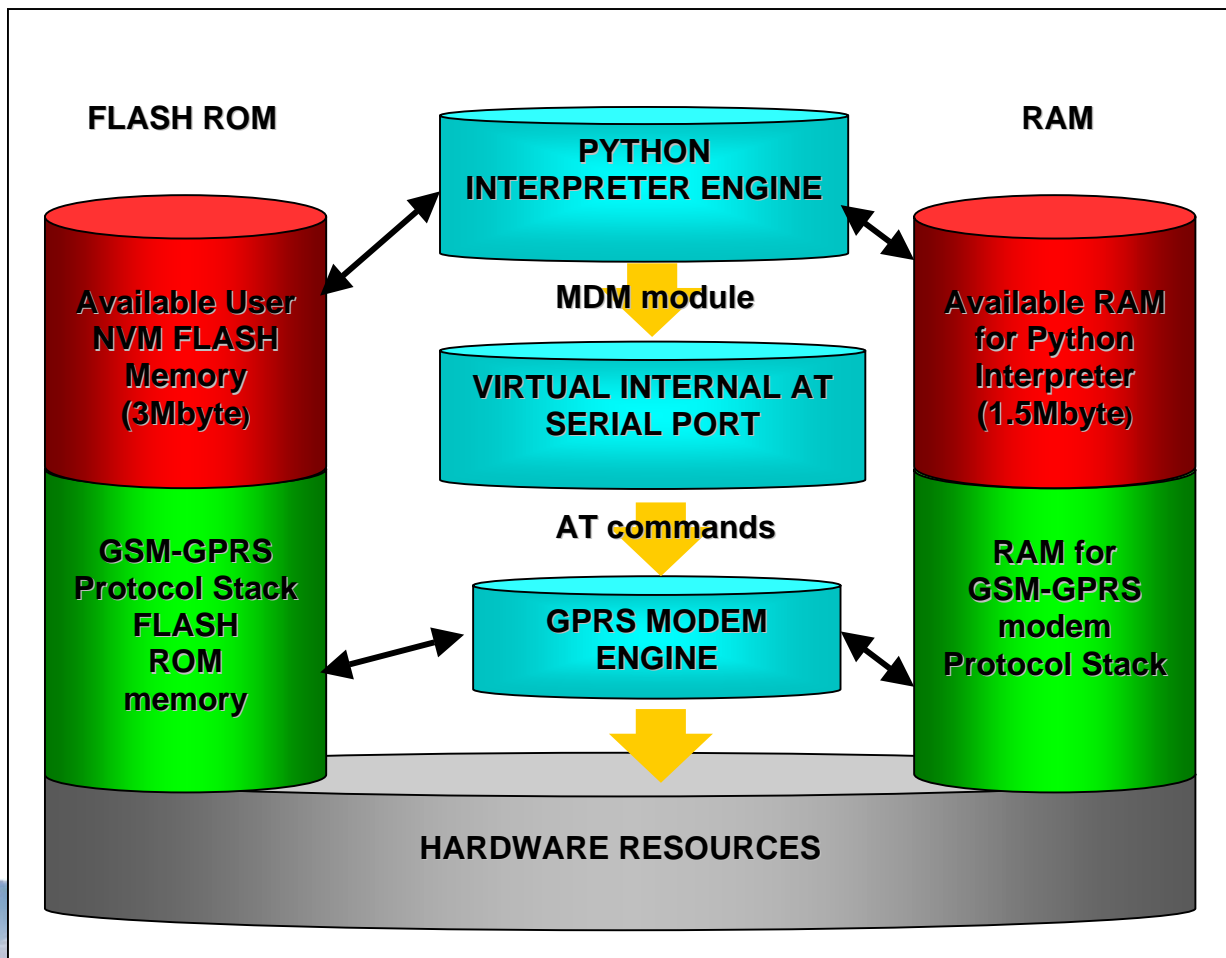
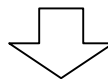

Product Description

80269ST10024a Rev. 0 - 19/09/06

3.3.3 Python implementation description

Python scripts are text files stored in NVM inside the **Telit module**. There's a file system inside the module that allows to write and read files with different names on one single level (no subdirectories are supported).

ATTENTION: it is possible to run only one Python script at the time.

The Python script is executed in a task inside the **Telit module** at the lowest priority, making sure this does not interfere with GSM/GPRS normal operations. This allows serial ports, protocol stack etc. to run independently from the Python script.

The Python script interacts with the **Telit module** functionality through four build-in interfaces.

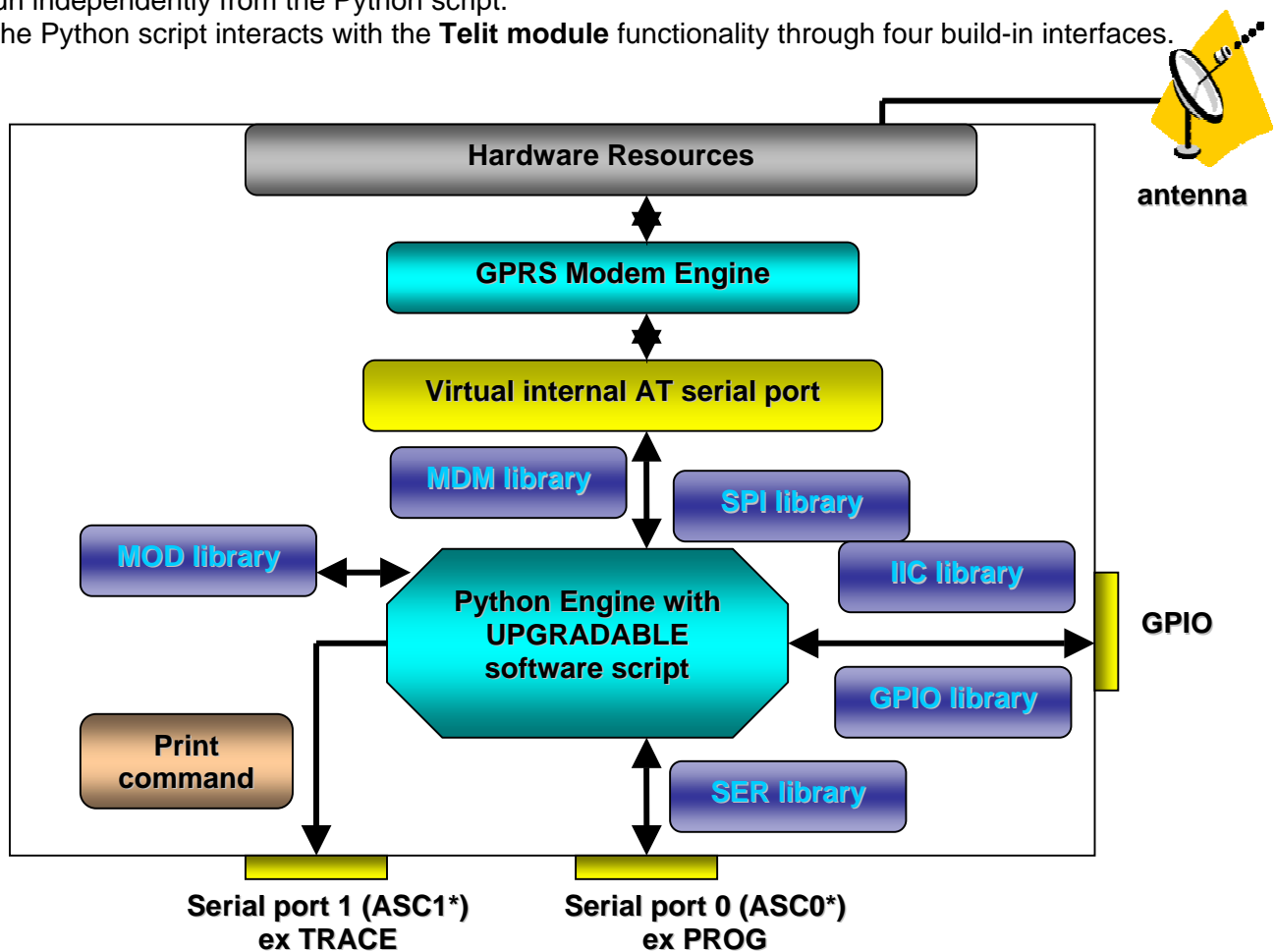

- **The MDM interface** is the most important one. It allows Python script to send AT commands, receive responses and unsolicited indications, send data to the network and receive data from the network during connections. It is quite the same as the usual serial port interface in the **Telit module**. The difference is that this interface is not a real serial port but just an internal software bridge between Python and mobile internal AT command handling engine. All AT



Product Description

80269ST10024a Rev. 0 - 19/09/06

commands working in the **Telit module** are working in this software interface as well. Some of them have no meaning on this interface, such as those regarding serial port settings. The usual concept of flow control keeps its meaning over this interface, but it's managed internally.

- **The SER interface** allows Python script to read from and write to the *real*, physical serial port where usually the AT command interface resides, for example to read NMEA information from a GPS device. When Python is running this serial port is free to be used by Python script because it is not used as AT command interface since the AT parser is mapped into the internal virtual serial port. No flow control is available from Python on this port.
- **The GPIO interface** allows Python script to handle general purpose input output faster than through AT commands, skipping the command parser and going directly to control the pins.
- **The MOD interface** is a collection of useful functions.
- **The IIC interface** is an implementation on the Python core of the IIC bus Master. It allows Python to create one or more IIC bus on the available GPIO pins.
- **The SPI interface** is an implementation on the Python core of the SPI bus Master. It allows Python to create one or more IIC bus on the available GPIO pins.

For the debug, the print command is directly forwarded on the EMMI TX pin (second serial port) at baud rate 115200bps 8N1.

3.3.4 Python core supported features

The Python core version is 1.5.2+ (string methods added to 1.5.2).

You can use all Python statements and almost all Python built-in types and functions.

Built-in types and functions not supported	Available modules (all others are not supported)
complex	marshal
float	imp
long	_main_
docstring	_builtin_
	sys
	md5

3.3.5 Python Build-in Custom Modules

Several build in custom modules have been included in the python core, specifically aimed at the hardware environment of the module.

The build in modules included are:

MDM	interface between Python and mobile internal AT command handling
------------	--



Product Description

80269ST10024a Rev. 0 - 19/09/06

4 AT Command Interface

The **Telit EZ10-QUAD-PY** can be driven via the serial interface using the standard AT commands³. The **Telit EZ10-QUAD-PY** is compliant with:

1. Hayes standard AT command set, in order to maintain the compatibility with existing SW programs.
2. ETSI GSM 07.07 specific AT command and GPRS specific commands.
3. ETSI GSM 07.05 specific AT commands for SMS (Short Message Service) and CBS (Cell Broadcast Service)
4. FAX Class 1 compatible commands

Moreover the **Telit EZ10-QUAD-PY** supports also Telit proprietary AT commands for special purposes.

The *GM862-QUAD-PY AT Commands Reference Guide* document, shows a dedicated detailed description of all supported AT commands and how to use the AT commands with the **Telit EZ10** through some example scripts.

³ The AT is an ATTENTION command and is used as a prefix to other parameters in a string. The AT command combined with other parameters can be set up in the communications package or typed in manually as a command line instruction.



Product Description

5 Service and SW / Firmware Update

The RS232 serial interface on the Terminal used for the communication with a PC can also be used to update the **Telit EZ10-QUAD-PY Terminal** firmware (Software).

The firmware update can be done with a specific software tool provided by Telit that runs on windows based PCs.

The update procedure requires switch-on the Terminal at a prompt within the running update tool. Thus, the power supply line shall be disconnected before the launch of the update tool on the PC and prepared for re-connection.

NOTE: Switching OFF the EZ10-QUAD-PY by disconnecting the external power supply line requires to wait enough time (depending on the HW version!) that the load capacitor of the DC/DC converter inside the EZ10-QUAD-PY discharges so that the module inside goes to OFF condition.

5.1 Step-by-Step upgrade procedure

First the program will erase the content of flash memory, then the program will write on the flash memory. To update the firmware of the module, we suggest the following procedure:

- Collect information about the Hardware and implemented version of Software by the command
 - AT+CGMR<enter>, which returns the Software version information;
 - AT+CGMM<enter>, which returns the Model Identification.
- Switch OFF the module.
- Run the file *TFI_xxxx.exe*. The following window should be displayed, Select the language preferred by pressing the correspondent button.



- The End User License Agreement will appear. Please, read it and accept the terms if you are going to proceed.



EZ10-QUAD-PY Terminal Product Description

80269ST10024a Rev. 0 - 19/09/06



- Press OK to the initial message.

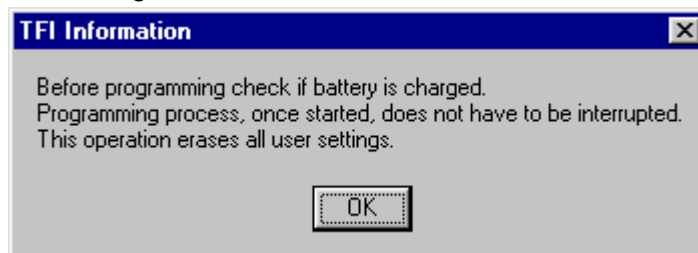

NOTE: In connection with the EZ10-QUAD-PY Terminal, charged battery has to be understood that the power supply must not be disconnected during the firmware update.

- Select the right COM port and speed. Note that to go faster than 115200 you need a special hardware on the PC. Then Press the Download button and within 5 seconds power-on the EZ10-QUAD-PY.

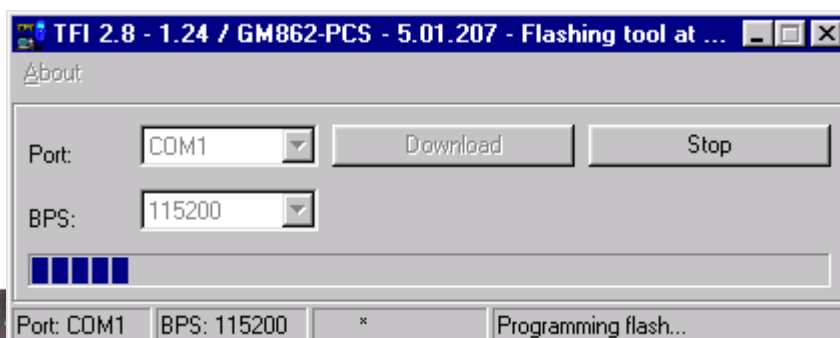

EZ10-QUAD-PY Terminal Product Description

80269ST10024a Rev. 0 - 19/09/06

Wait for the end of programming green message OK

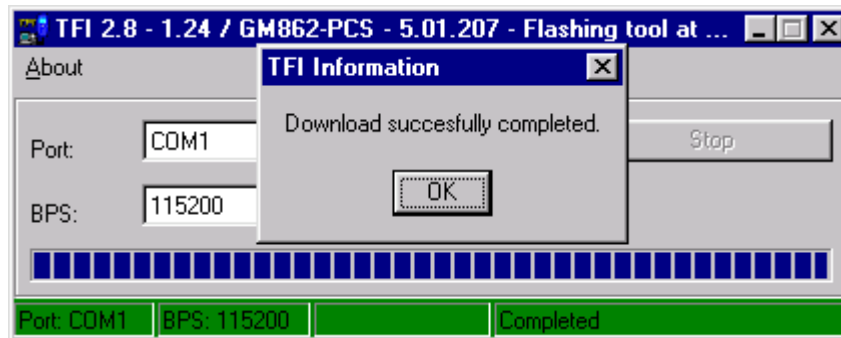

The **Telit EZ10-QUAD-PY Terminal** is now programmed with the new firmware.



Product Description

80269ST10024a Rev. 0 - 19/09/06

6 EZ10-QUAD-PY Technical Support

Telit's technical support to [Telit EZ10 wireless modem](#) customers:

- All available technical documentation is included for download into the Website www.telit.com >Products >Modules >EZ10-QUAD-PY.
- Telit's engineering support is accessible via a selective E-Mail service with 48h replies assured under normal conditions.

In case of technical inquiries, the following information would be relevant to optimize Technical Support:

- Write Company, Project, Product Type, Trouble and Person reference in the "subject" field of the e-mail so that all mails can be easily retrieved also after several forwards
- The e-mail text should report:
 - Product Type
 - Delivery Date
 - Serial Number S/N of the EZ10-QUAD-PY Terminal
 - LOT N.
 - HW and SW code xSxxxxxxHxx
 - HW version of the EZ10-QUAD-PY Terminal: v.xx
 - Installed SW version (AT+CGMR)
 - IMEI (AT+CGSN)
 - Description of the Application, reference to its version (SW, HW)
 - SIM Type (issued by which Mobile Network Operator of Home PLMN or Service Provider and SIM type & supplier)
 - Network Conditions: location, registered network, coverage (AT#CSURV)
 - Antenna type
 - Used Services (MO, MT, voice, SMS, data, fax, GPRS)

...and then the question or trouble:

- Command & Response sequences
- Listing of the relevant parts of a Python Script
- Signal / pin, timing, levels...

Thank you!



EZ10-QUAD-PY Terminal
Product Description

80269ST10024a Rev. 0 - 19/09/06



Product Description

8 List of Acronyms

ACM	Accumulated Call Meter
ASCII	American Standard Code for Information Interchange
AT	Attention commands
CB	Cell Broadcast
CBS	Cell Broadcasting Service
CCM	Call Control Meter
CLIP	Calling Line Identification Presentation
CLIR	Calling Line Identification Restriction
CMOS	Complementary Metal-Oxide Semiconductor
CR	Carriage Return
CSD	Circuit Switched Data
CTS	Clear To Send
DAI	Digital Audio Interface
DCD	Data Carrier Detected
DCE	Data Communications Equipment
DRX	Data Receive
DSR	Data Set Ready
DTA	Data Terminal Adaptor
DTE	Data Terminal Equipment
DTMF	Dual Tone Multi Frequency
DTR	Data Terminal Ready
EMC	Electromagnetic Compatibility
ETSI	European Telecommunications Equipment Institute
FTA	Full Type Approval (ETSI)
GPRS	General Radio Packet Service
GSM	Global System for Mobile communication
HF	Hands Free
I²C, IIC	Inter IC Bus
IMEI	International Mobile Equipment Identity
IMSI	International Mobile Subscriber Identity
IRA	Internationale Reference Alphabet
ITU	International Telecommunications Union
IWF	Inter-Working Function
LCD	Liquid Crystal Display
LED	Light Emitting Diode
LF	Linefeed
ME	Mobile Equipment
MMI	Man Machine Interface
MO	Mobile Originated
MS	Mobile Station



Product Description

80269ST10024a Rev. 0 - 19/09/06

MT	Mobile Terminated
OEM	Other Equipment Manufacturer
PB	Phone Book
PDU	Protocol Data Unit
PH	Packet Handler
PIN	Personal Identity Number
PLMN	Public Land Mobile Network
PUCT	Price per Unit Currency Table
PUK	PIN Unblocking Code
RACH	Random Access Channel
RLP	Radio Link Protocol
RMS	Root Mean Square
RTS	Ready To Send
RI	Ring Indicator
SAR	Specific Absorption Rate (e.g. of the body of a person in an electromagnetic field)
SCA	Service Center Address
SIM	Subscriber Identity Module
SMD	Surface Mounted Device
SMS	Short Message Service
SMSC	Short Message Service Center
SPI	Serial Protocol Interface
SS	Supplementary Service
TIA	Telecommunications Industry Association
UDUB	User Determined User Busy
USSD	Unstructured Supplementary Service Data



Product Description

80269ST10024a Rev. 0 - 19/09/06

9 Document Change Log

Revision	Date	Changes
ISSUE #0 DRAFT	06/06/2006	First Issue
ISSUE #0	19/09/2006	2.5.1.1 Hardware Identification: added new label 3.3.3 Python Implementation Description 4 AT Commands Interface: eliminated AT commands table

