

Hardware Interface Description



EZ10 GPS PY Terminal Telit Cellular GPS Engine

Version: 06.00A
EZ10 GPS PY Terminal_HD_V06.00A 1.Jan.2007

1. Key Features of the EZ10 GPS PY Terminal

Feature	Implementation
General	
Incorporates GM862 GPS module	The Telit GM862 GPS PY module handles all processing for audio, signal and data within the EZ10 GPS PY Terminal.
Frequency bands	Quad band: GSM 850/900/1800/1900MHz
Power supply	Single supply voltage 5V to 30V
Operating temperature	-20°C to +70°C ambient temperature
Physical	Dimensions: 107mm x 64m x 33m Weight: 160g
RoHS, WEEE	All hardware components are fully compliant with the EU RoHS and WEEE Directives
GSM / GPRS features	
Data transfer	GPRS · Multislot Class 10 CSD · 2.4, 4.8, 9.6 kbps · USSD PPP-stack for GPRS data transfer
SMS	· Point-to-point MT and MO · Text and PDU mode · Storage: SIM card plus 20 SMS locations in mobile equipment · Transmission of SMS alternatively over CSD or GPRS. Preferred mode can be user defined.
Fax	Group 3; Class 1
Audio	Speech codecs: · Half rate HR · Full rate FR · Enhanced full rate EFR · Adaptive Multi Rate AMR Line echo cancellation
Software	
AT commands	AT-Hayes GSM 07.05 and 07.07
TCP/IP Stack.	TCP/IP stack Access by AT commands
Firmware update	Upgradeable via serial interface.

PYTHON platform	Major benefits: seamless integration into PYTHON applications, no need for application microcontroller, extremely cost-efficient hardware and software design – ideal platform for industrial GSM applications. The memory space available for PYTHON programs is 3.0 MB flash file system and 1.5 MB RAM. Application code and data share the space in the flash file system and in RAM.
Interface	
Serial interface	<ul style="list-style-type: none"> · 8-wire modem interface with status and control lines, unbalanced, asynchronous · Fixed bit rates: 300 bps to 115,200 bps · Autobauding: 300 bps to 38,800 bps · Multiplex ability according to GSM 07.10 Multiplexer Protocol.
I ² C	bus for transmission rates up to 100kbps. The I ² C interface is not available when using as GPIO interface on the same pinout.
Audio	Analog (Microphone bios ready, Speaker with 3w amplifier)
SIM interface	Supported SIM cards: 3V, 1.8V
Antenna	Connected via antenna SMA connector or internal antenna
Power on/off, Reset	
Power-on	Automatic on when power supply turn on Option: ONOFF line on IO interface connector
Power-off	Normal switch-off by AT
Reset	Shutdown and reset by AT command
Special features	
Real time clock	Timer functions via AT commands
GPIO	4 I/O pins of the application interface are programmable as GPIO. Programming is done via AT commands. Alternatively,
Phonebook	SIM and phone
GPS	High sensitivity for indoor reception up to -159 dBm. Fast TTFF's at low signal levels. Hot starts less then 2 seconds. Support 20- Channel GPS. GPS NMEA 0183 output format.

2. Interface Description

2.1 Overview

EZ10 GPS PY Terminal provides the following connectors for power supply, interface and antennas:

1. SMA connector (female) for GSM antenna.
2. Led's GSM and Power indicators.
3. 9-pole (female) SUB-D plug for RS-232 serial interface.
4. SMA connector (female) for GPS antenna.
5. 4-pole 3mm Micro Mate-N-LOK connector for power supply and GPIO3.
6. SIM card holder.
7. 6-pole RJ11 plug (female) for 4 GPIOs or option audio, such as a Microphone and Speaker.
Optional Audio Hand free card 3w, Optional Relay card for GPIO5.



Figure 1: EZ10 GPS PY Terminal front view



Figure 2: EZ10 GPS PY Terminal side A view



Figure 3: EZ10 GPS PY Terminal side B view

2.2 Block Diagram

Figure 4 shows a block diagram of a sample configuration that incorporates a EZ10 GPS PY Terminal and typical accessories.

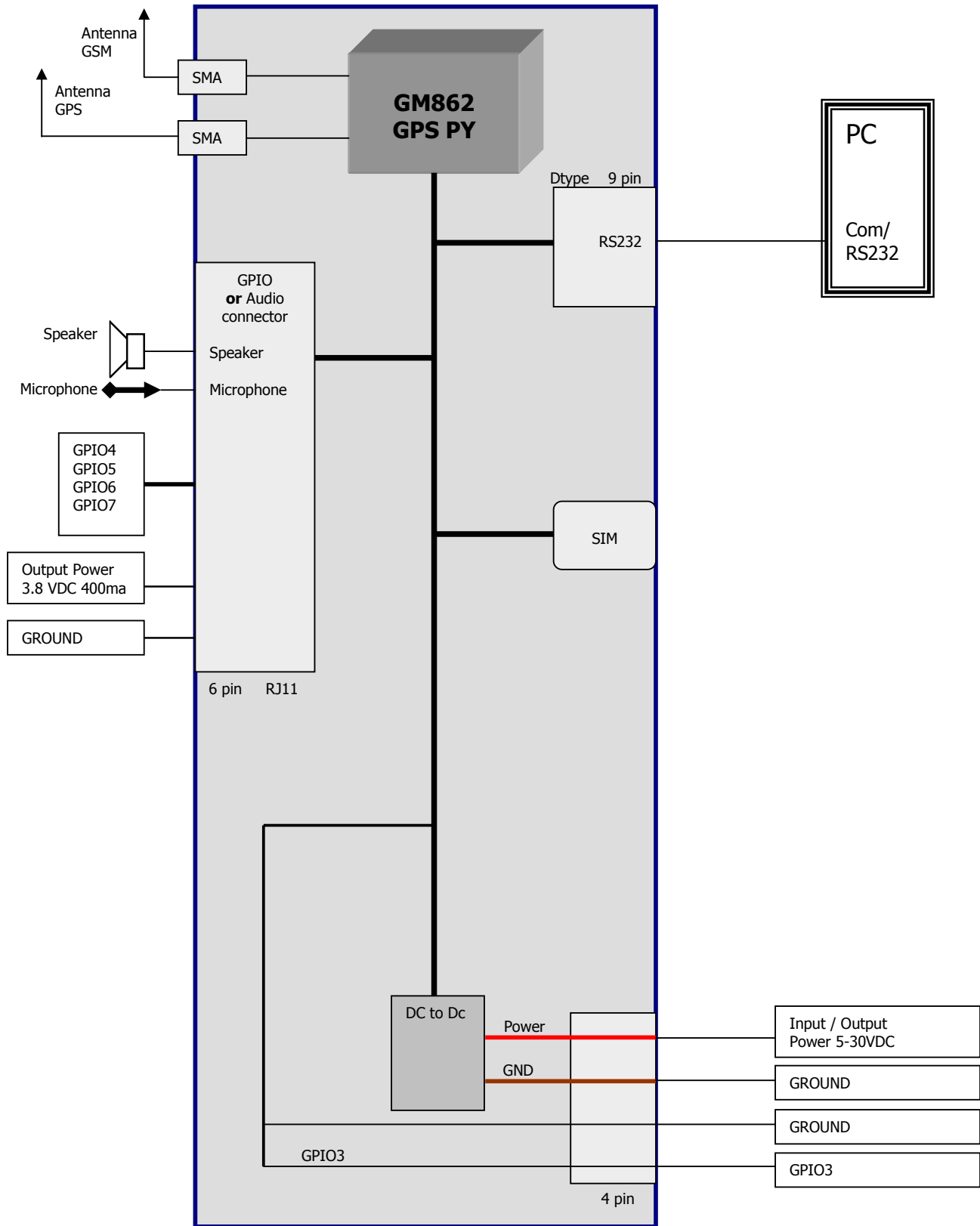

Figure 4: Block diagram

2.3 Power Supply

The power supply of the EZ863 Terminal has to be a single voltage source of POWER=5V-30V capable of providing a peak during an active transmission. The EZ863 Terminal is protected from supply voltage reversal. An internal fuse ensures an electrical safety according to EN60950. This fuse is not removable.

Pin	Signal name	Use
1	POWER	Input Power supply range 5-30V
2	GPIO3	GPIO 3
3	GND	Ground
4	GND	Ground

Table 1: Pin assignment of the plug for power supply and relay

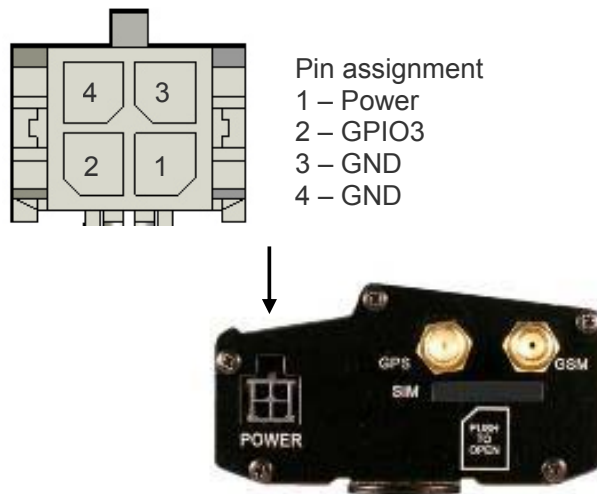

Figure 5: Male 4-pole plug for power supply.

2.3.1 Supply voltage requirements

The DC power supply must be connected to the POWER input:

- Input voltage range 5 - 30V DC
- Nominal Voltage 12V DC
- Power Supply current rating: min. 1,2A @12V
- Power Supply ripple: max. 120mV
- Input current in idle mode: 20mA @ 12V
- Input average current in communication mode: 100mA @ 12V

2.4 Switch on EZ10 GSP PY Terminal

- Switch on via automatic power supply unit:

By connecting the EZ10 GPS PY Terminal with the power supply unit, the EZ10 GPS PY Terminal starts to work.

2.4.1 Reset EZ10 GPS PY Terminal

An easy way to reset the EZ10 GPS PY Terminal is entering the command AT.

2.4.2 Switch off EZ10 GSP PY Terminal

- Software controlled shutdown by AT command:

The AT command lets EZ10 GPS PY Terminal log off from the network and allows the software to enter into a the secure state and save data before disconnecting the power supply.

The mode is referred to Power-down mode. In this mode only the RTC stays active.

2.4.3 Disconnecting Power Supply

Before disconnecting the power supply from the POWER pin make sure the EZ10 GPS PY Terminal is in a safe condition. A safe condition is waiting 1s after the "SHUTDOWN" result code has been indicated.

2.6 RS-232 Interface

The serial interface of the EZ10 GPS PY Terminal is intended for the communication between the GSM module and the host application. This RS-232 interface is a data and control interface for transmitting data, AT commands and providing multiplexed channels. EMC immunity complies with the vehicular environment requirements according to EN 301 489-7.

The user interface of the EZ10 GPS PY Terminal is accessible from a Data Terminal Equipment DTE connected to the RS232 interface and it is managed by AT commands according to the GSM 07.07 and 07.05 specification and the supported commands are listed in the AT Commands Reference Guide.

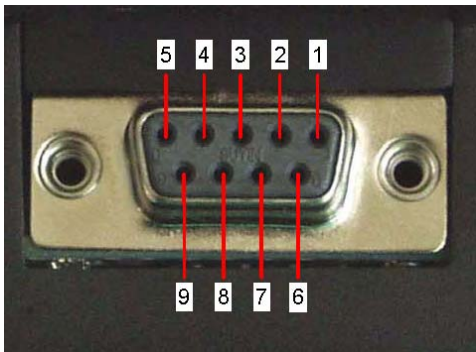

Figure 11: Pin assignment RS-232 (D-Sub 9-pole female)

Pin no.	Signal name	I/O	Function of application
1	DCD	O	Data Carrier Detected
2	RXD	O	Receive Data
3	TXD	I	Transmit Data
4	DTR	I	Data Terminal Ready
5	GND	-	Ground
6	DSR	O	Data Set Ready
7	RTS	I	Request To Send
8	CTS	O	Clear To Send
9	RING	O	Ring Indication

Table 4: D-Sub 9-pole female RS232

Connector type on the terminal is:

- RS-232 through D9-pin female
- Baud rate from 300 to 115.200 bit/s
- Autobauding (300 to 38.400 bit/s)
- Short circuit (to Ground) protection on all outputs.
- Input voltage range: -12V to +12V

2.6.1 The PC as Data Terminal Equipment (DTE)

The software application for using the PC RS232 standard serial interface (COM-port) as Data Terminal Equipment (DTE) is usually Hyper Terminal. Connect using the COM-port to which the EZ10 GPS PY Terminal is connected with the following settings:

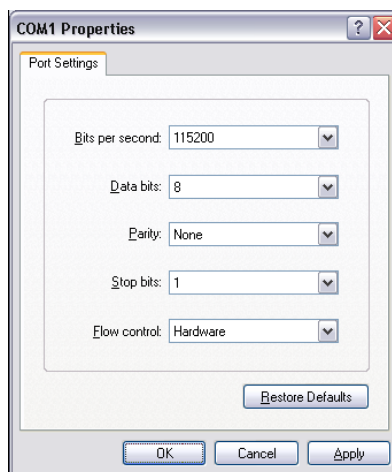

2.7 Option - GPIO Interface

The GPIO interface provides 4 inputs / outputs

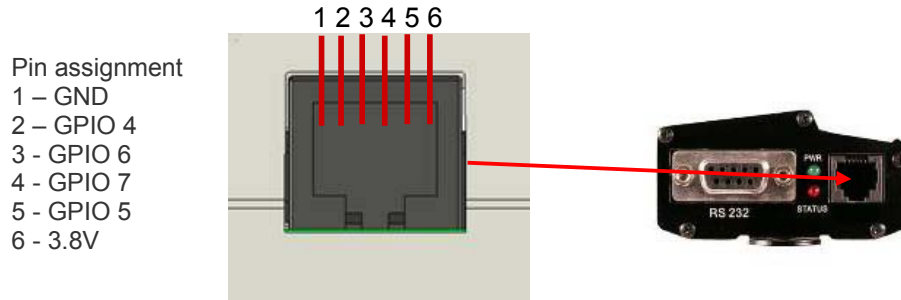

Figure 12: Audio RJ11 plug (6/4-pole female)

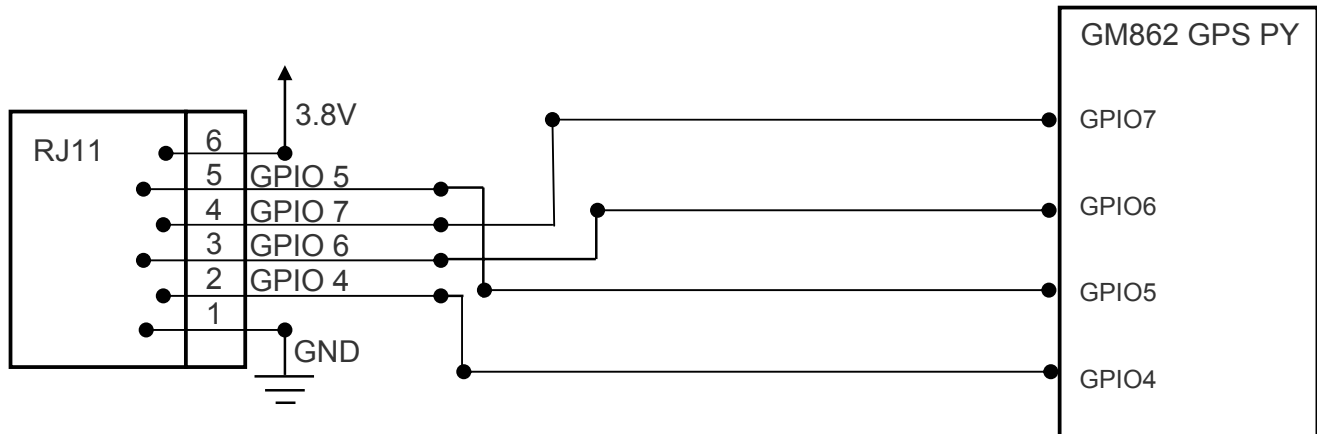

Figure 13: GPIO block diagram

2.5 Signal States after Startup

Table 7 describes the various states each interface pin passes through after startup and during operation. The state of several pins will change again once the respective interface is activated or configured by AT command.

RJ11 6 Pin Connector	Signal name	Defined state After initialization
2	GPIO4	Tri state
3	GPIO6	Tri state
4	GPIO7	Tri state
5	GPIO5	Tri state

Table 2: Signal states

2.5.1 GPIO Interface Specification

Where not specifically stated, all the interface circuits work at 2.62V CMOS logic levels.

All General Purpose input / output are connected to the related pins of the Telit module over a 100 Ohms series resistor. The following table shows the logic level specifications in the EZ10 GPS PY terminal interface circuits:

LEVEL	MIN	MAX
Input high level	2.1 V	3.6V
Input low level	0 V	0.5 V
Output high level	2.2 V	3.0 V
Output low level	0 V	0.35

Table 3: GPIO Signal states level

2.10.1 GPIOs

The EZ10 GPS PY Terminal provides 4 GPIO pins at the 6 pins interface connector.

Each GPIO line is ESD protected and a serial resistor of 100 Ohm is added. This avoids short circuits, The signal direction (input/output) of the GPIO lines is selectable with AT commands.

Figure 11 shows the position of the GPIO pins at the IO interface connector. When the EZ10 GPS PY Terminal starts up, all GPIO pins are set to high-impedance state after initializing, all 4 GPIO have optional internal pull-up resistors of 47k. This is necessary to keep these pins from floating or driving any external devices before all settings are done by AT command.

Using the RFTX Output GPIO5

The GPIO5 pad, when configured as RFTX Output, is controlled by the GM862 GPS module and will rise when the GM862 GPS starts transmit and fall after stop to transmit.

Using the Alarm Output GPIO6

The GPIO6 pad, when configured as Alarm Output, is controlled by the GM862 GPS module and will rise when the alarm starts and fall after the issue of a dedicated AT command. This output can be used to power up the EZ10 GPS PY controlling microcontroller or application at the alarm time, giving you the possibility to program a timely system wake-up to achieve some periodic actions and completely turn off either the application and the GM862 GPS during sleep periods, dramatically reducing the sleep consumption to few μ A. In battery powered devices this feature will greatly improve the autonomy of the device.

Using the Buzzer Output GPIO7

The GPIO7 pad, when configured as Buzzer Output, is controlled by the GE862 GPS module and will drive with appropriate square waves a Buzzer driver. This permits to your application to easily implement Buzzer feature with ringing tones or melody played at the call incoming, tone playing on SMS incoming or simply playing a tone or melody when needed by your application.

2.10.10 3.8V Supply

The 3.8v pin at the 6 pins interface connector may be used for supplying external circuit devices or applications. The 3.8v is the same power supply to GM862 GPS, The 3.8v parameters:
output voltage = 3.8V @ max. 400mA

2.7 Option - Audio Interface

The audio interface provides one analog input for a microphone and one analog output for Speaker.

- The microphone input and the Speaker output are balanced.

Option Hand Free card

- For electret microphone a supply source is implemented.
- For speaker 3W amplifier implemented output 4ohm.

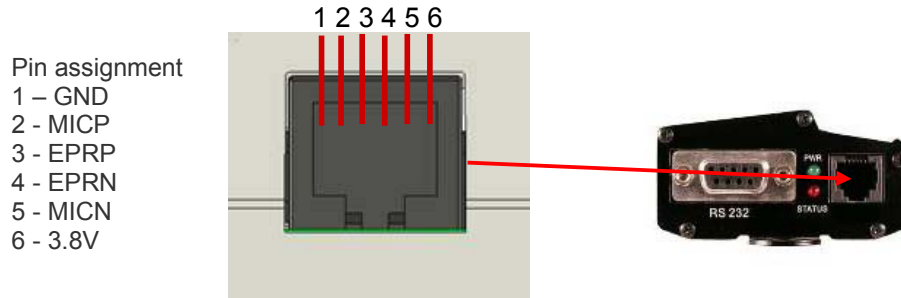

Figure 12: Audio RJ11 plug (6/4-pole female)

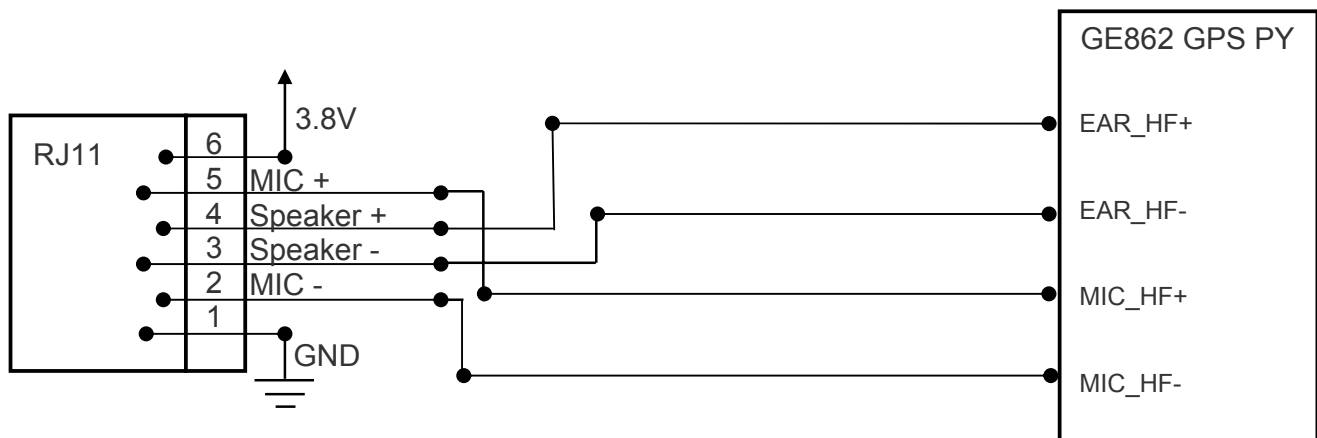

Figure 13: Audio block diagram

Sample Commands for EZ10 GPS PY Audio operation

1	AT#CAP=	1	Audio Path
2	AT#SHFEC=	1	Echo Canceller
3	AT+CLVL=	0 - 14	Speaker Gain
4	AT#HFMICG=	0 - 7	Microphone Gain

Send in One Line all 4 AT command in top table	AT#CAP=1;#SHFEC=1;+CLVL=10;#HFMICG=3
Get Values	AT#CAP?;#SHFEC?;+CLVL?;#HFMICG?

2.7.1 Supported Audio Modes

The audio interface can be configured by AT commands. In audio mode HAND FREE, the default gain 4 in the MIC_HF and the default gain 10 in the EAR_HF.

Please note that the Hand Free audio interface is connected in the EZ10 GPS PY Terminal.

2.7 Antenna Interface

In order to send or receive data connect an external RF antenna to the SMA connector which is internally connected to the RF signal of the GSM module.

Please consider that the recommended antenna equipment has been chosen to achieve optimum RF performance when operating the EZ10 GPS PY Terminal.

NOTE: Before connecting the EZ10 GPS PY to a Power Supply source, a suitable Antenna shall be As accessory, a magnetic surface mount antenna with 2.5dB gain, 2.5m of coaxial cable and The antenna has to be installed with care in order to avoid any interference with other electronic devices and has to guarantee a minimum distance from persons (20 cm). In case this requirement cannot be satisfied, the system integrator has to assess the final product against the SAR For a good efficiency of the antenna and minimum interference with other electronic systems, a space of min. 40 cm around the radiating part should be free, at least of electrically conducting materials (except the ground plane on which it is attached). Less distance and less obstacles there are between the antenna connected to the EZ10 GSP PY Terminal and the antenna of the GSM/GPRS network base station, the less power is radiated by the Terminal under normal conditions and the higher is the safety margin in case of disturbances. A check of eventual interferences can be made when the EZ10 GPS PY Terminal transmits at maximum power level to register to a GSM 900 network (see frequency channel numbers), The EZ10 GPS PY includes a SMA female, and class 4 (2W) co-axial connector for the antenna to be connected shall fulfill the following requirements:

Frequency range	Depending by frequency band(s) provided by the network operator, the customer shall use the most suitable antenna for that/those band(s)
Bandwidth	80 MHz in EGSM 900, 70 MHz if GSM 850, 170 MHz in DCS, 140 MHz PCS band
Gain	1.5dBi \leq Gain $<$ 3dBi (referenced to isotropic radiator)
Impedance	50 Ohm
Input power	$>$ 2 W peak power
VSWR absolute max	\leq 10:1
VSWR recommended	\leq 2:1

Table 5: Antenna specification

2.8.1 Operating Frequency

The operating frequencies in GSM, DCS, PCS modes are conform to the GSM specifications.

Mode	Freq. TX (MHz)	Freq. RX (MHz)	Channels (ARFC)	TX - RX offset
E-GSM-900	890.0 - 914.8	935.0 - 959.8	0 - 124	45 MHz
	880.2 - 889.8	925.2 - 934.8	975 - 1023	45 MHz
GSM-850	824.2 - 848.8	969.2 - 893.8	128 - 251	45 MHz
DCS-1800	1710.2 - 1784.8	1805.2 - 1879.8	512 - 885	95 MHz
PCS-1900	1850.2 - 1909.8	1930.2 - 1989.8	512 - 810	80 MHz

Table 6: Operating frequencies

Transmitter output power

GSM-850 / 900

The EZ10 GPS PY modem in GSM-850/900 operating mode are class 4 in accordance with the specification which determine the nominal 2W peak RF power (+33dBm) on 50 Ohm.

DCS-1800 / PCS-1900

The EZ10 GPS PY modem in DCS-1800/PCS-1900 operating mode are of class 1 in accordance with the specifications which determine the nominal 1W peak RF power (+30dBm) on 50 Ohm.

Reference sensitivity

GSM-850 / 900

The sensitivity of the EZ10 GPS PY wireless modem according to the specifications for the class 4 GSM-850/900 portable terminals is -107dBm typical in normal operating conditions.

DCS-1800 / PCS-1900

The sensitivity of the EZ10 GPS PY wireless modem according to the specifications for the class 1 portable terminals DCS-1800 / PCS-1900 is -106 dBm typical in normal operating conditions.

2.9 SIM Interface

The SIM interface is intended for 3V and 1.8V SIM cards. The card holder is a five wire interface according to GSM 11.11. A sixth pin has been added to detect whether or not the SIM card drawer is inserted. Removing and inserting the SIM card during operation requires the software to be reinitialized. Therefore, after reinserting the SIM card it is necessary to restart EZ10 GPS PY Terminal.

2.11 Status LED

Red LED displays the network status of the EZ10 GPS PY Terminal.

Green LED displays the POWER status of the EZ10 GPS PY Terminal .

Red LED status	Device Status
permanently on	a call is active
fast interrupt sequence (period 0,5s, Ton 1s)	Net search / Not registered / turning off
slow interrupt sequence (period 0,3s, Ton 3s)	Registered full service
permanently off	device off

Table 10: RED LED Status

3. GPS

3.1 GPS Antenna Requirements

The GM862 GPS module is not provided with an internal LNA amplifier. The use of an active antenna is important to achieve a good performance.

The module is provided of an Antenna supply circuit with the following characteristics:

- Supply voltage referred to VBATT (3.4 to 4.2 V DC)
- Supply enable controlled internally by the BB
- Current measurement circuit (readable also with AT commands)
- Voltage measurement circuit (readable also with AT commands)
- HW Protection for Antenna Short Circuit (if consumption exceeds 40mA)

As suggested on the Product Description the external active antenna for a EZ10 GPS PY device shall fulfill the following requirements:

ANTENNA REQUIREMENTS	
Frequency range	1575.42 MHz (GPS L1)
Bandwidth	+ - 1.023 MHz
Gain	1.5 dBi < Gain < 4.5 dBi
Impedance	50 ohm
Amplification	Typical 25dB (max 27dB)
Supply voltage	Must accept from 3 to 5 V DC
Current consumption	Typical 20 mA (40 mA max)

Table 11: GPS Antenna requirements

4. Mechanical Characteristics

Weight	160g
Dimensions (max) L x W x H	107 mm x 83mm x 33mm
Temperature range	-20°C to +70°C ambient temperature
Mechanical vibrations Amplitude	7.5mm at 5-200Hz sinus
Air humidity	5% - 85%

Table 11: Mechanical characteristics

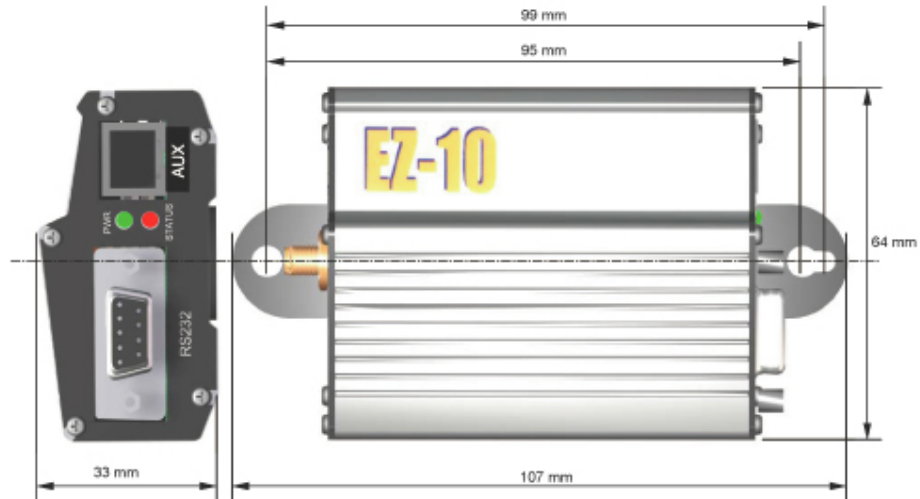

Figure 18: Mechanical measurements

5. ACCESSORIES

5.2 Power Supply

This chapter provides specifications for the power supply which serves the Terminal. The power supply we recommended is 12V 1.2A made by HOPSHING part number EZ12V1.2A. The type of the receptacle assembled on the EZ10 GPS PY Terminal is 4 pin Micro Mate-N-LOK 3mm from MOLEX. Mating headers can be chosen from the MOLEX Micro Mate-N-LOK Series. For latest product information <http://www.molex.com>

5.4 Power cable

This chapter provides specifications for the power cable which serves the Terminal. The power Cable we recommended is 30V 1.2A part number EZpowerCable2m. The type of the receptacle assembled on the EZ10 GPS PY Terminal is 4 pin Micro Mate-N-LOK 3mm from MOLEX. Mating headers can be chosen from the MOLEX Micro Mate-N-LOK Series. For latest product information <http://www.molex.com>

5.2 GSM antenna

This chapter provides specifications for the GSM antennas which serves the Terminal.

We recommended 4 types of GSM antennas with SMA connector:

900/1800Mhz 2.5dBm 3 meter cable part number EZantennaGSM2.5db9001800.

850/1900Mhz 2.5dBm 3 meter cable part number EZantennaGSM2.5db8501900.

900/1800/1900Mhz 1dBm 5 cm 90 degree SMA part number EZantennaGSM1db90018001900.

5.2 GPS antenna

This chapter provides specifications for the GPS antennas which serves the Terminal.

We recommended 2 types of GPS antennas with SMA connector:

1500Mhz _dBm 5 meter cable part number EZantennaGPS5m.

6. SAFETY RECOMMENDATIONS

READ CAREFULLY

Be sure the use of this product is allowed in the country and in the environment required. The use of this product may be dangerous and has to be avoided in the following areas:

Where it can interfere with other electronic devices in environments such as hospitals, airports, aircrafts, etc. Where there is risk of explosion such as gasoline stations, oil refineries, etc. It is responsibility of the user to enforce the country regulation and the specific environment regulation. Do not disassemble the product; any mark of tampering will compromise the warranty validity. We recommend following the instructions of the hardware user guides for a correct wiring of the product. The product has to be supplied with a stabilized voltage source and the wiring has to be conforming to the security and fire prevention regulations. The product has to be handled with care, avoiding any contact with the pins because electrostatic discharges may damage the product itself. Same cautions have to be taken for the SIM, checking carefully the instruction for its use. Do not insert or remove the SIM when the product is in power saving mode. The system integrator is responsible of the functioning of the final product; therefore, care has to be taken to the external components of the module, as well as of any project or installation issue, because the risk of disturbing the GSM network or external devices or having impact on the security. Should there be any doubt, please refer to the technical documentation and the regulations in force. Every module has to be equipped with a proper antenna with specific characteristics. The antenna has to be installed with care in order to avoid any interference with other electronic devices and has to guarantee a minimum distance from the body (20 cm). In case of this requirement cannot be satisfied, the system integrator has to assess the final product against the SAR regulation. The European Community provides some Directives for the electronic equipments introduced on the market. All the relevant information's are available on the European Community website:

<http://europa.eu.int/comm/enterprise/rte/dir99-5.htm>

The text of the Directive 99/05 regarding telecommunication equipments is available, while the applicable Directives (Low Voltage and EMC) are available at:

http://europa.eu.int/comm/enterprise/electr_equipment/index_en.htm