

# EZ864 CDMA Terminal Telit Cellular GSM Engine



**Version: 01.01**

**EZ864 CDMA Terminal\_HD\_V01.01 06.Mer.2008**

# Hardware Interface Description

## 1. Hardware Features of the EZ864 CDMA Terminal

Feature	Implementation
Incorporates CC864 module	The Telit CC864 CDMA module handles all GSM processing for, signal and data within the EZ864 CDMA Terminal.
Frequency bands	Quad band: GSM 850/900/1800/1900MHz
Power supply	Single supply voltage 5V to 30V
Operating temperature	-20°C to +70°C ambient temperature
Physical	Dimensions: 83mm x 64m x 33m Weight: 150g
RoHS, WEEE	All hardware components are fully compliant with the EU RoHS and WEEE Directives
4 GPIO inputs	4 input zones or can be set to: <ul style="list-style-type: none"><li>• 2 outputs 250ma each</li><li>• 2 inputs for 4-20ma sensors</li></ul>
1 internal relay	1 relay 1A 30V maximum

## 2. Interface Description

### 2.1 Overview

EZ864 CDMA Terminal provides the following connectors for power supply, Interface and antennas:

1. SMA connector (female) for GSM antenna
2. 4-pole 3mm Micro Mate-N-LOK connector for power supply, Internal relay output
3. SIM card holder
4. 9-pole (female) SUB-D plug for RS-232 serial interface
5. Led GSM and GPIO
6. 6-pole RJ11 plug (female) for GPIO



Figure 1: EZ864 CDMA Terminal side A view



Figure 2: EZ864 CDMA Terminal side B view

## 2.2 Block Diagram

Figure 3 shows a block diagram of a sample configuration that incorporates a EZ864 CDMA Terminal and typical accessories.

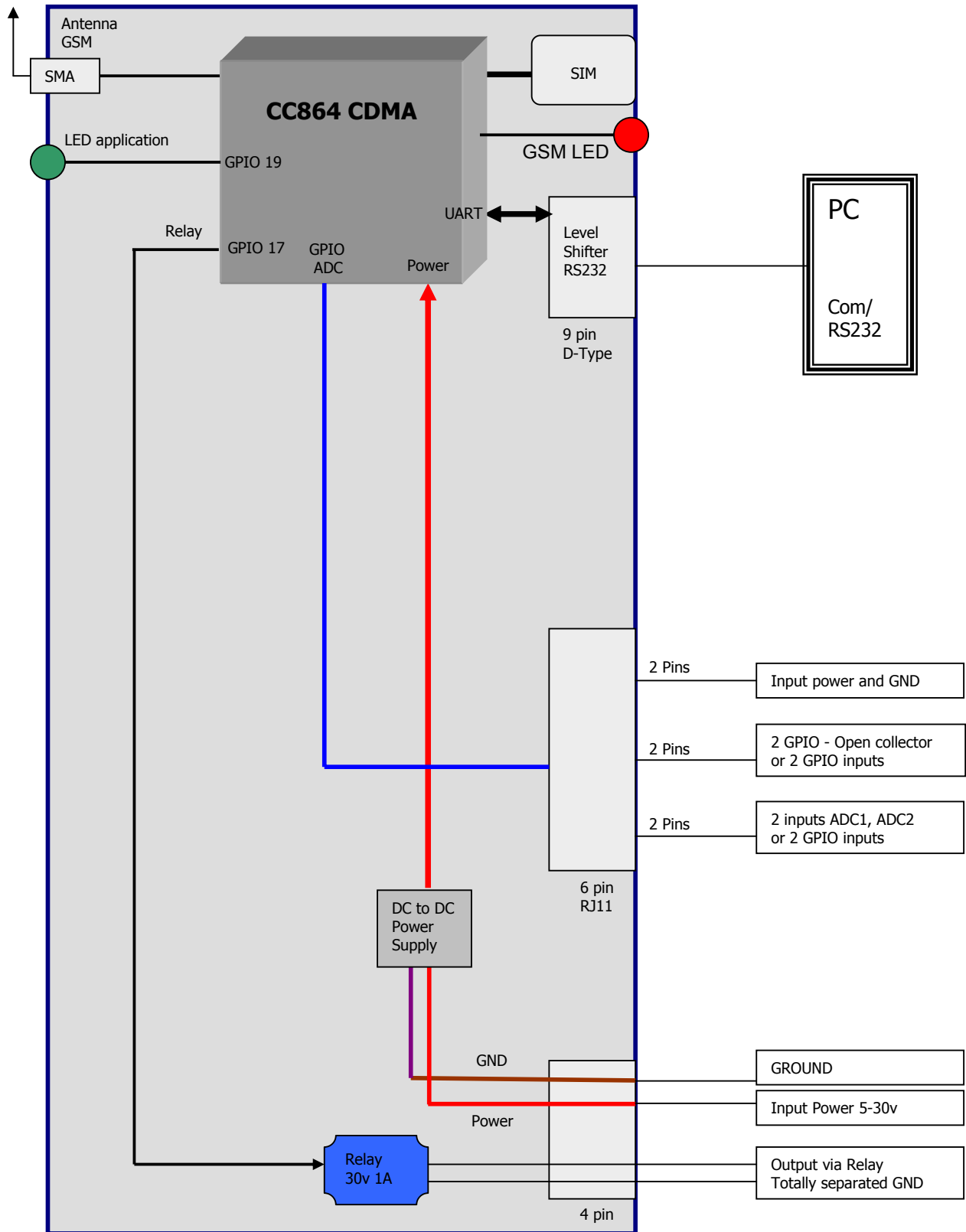

Figure 3: Block diagram

EZ864 CDMA Terminal Hardware Interface Description  
Released

## 2.3 Power Supply

The power supply of the EZ864 CDMA Terminal has to be a single voltage source of POWER 5V-30V capable of providing a peak during an active transmission. The EZ864 CDMA Terminal is protected from supply voltage reversal. An internal fuse ensures an electrical safety according to EN60950. This fuse is not removable. A fast acting fuse 0.8A with melting is necessary to use with the EZ864 CDMA Terminal at a 24V power supply system for vehicles. The power supply must be compliant with the EN60950 guidelines.

Pin	Signal name	Use
1	POWER	Input Power supply range 5-30V
2	Relay	Internal Relay leg A
3	GND	Ground
4	Relay	Internal Relay leg B

Table 1: Pin assignment of the plug for power supply and relay

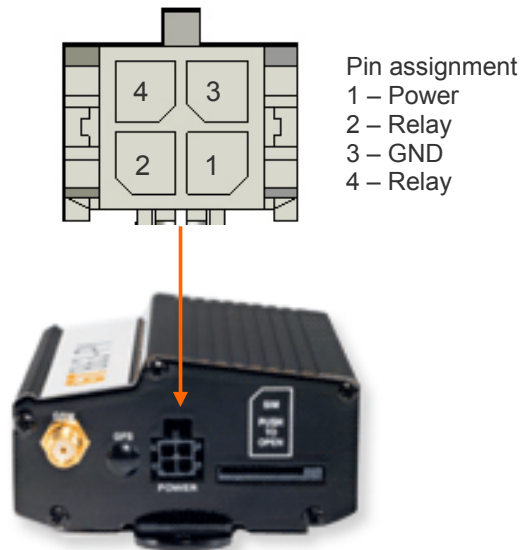

Figure 4: Male 4-pole plug for power supply and Relay output.

### 2.3.1 Supply voltage requirements

The DC power supply must be connected to the POWER input:

- Input voltage range 5 - 30V DC
- Nominal Voltage 12V DC
- Power Supply current rating: min. 1,2A @12V
- Power Supply ripple: max. 120mV
- Input current in idle mode: 20mA @ 12V
- Input average current in communication mode: 100mA @ 12V

## 2.4 RS-232 Interface

The serial interface of the EZ864 CDMA Terminal is intended for the communication between the GSM module and the host application. This RS-232 interface is a data and control interface for transmitting data, AT commands and providing multiplexed channels. EMC immunity complies with the vehicular environment requirements according to EN 301 489-7.

The user interface of the EZ864 SDMA Terminal is accessible from a Data Terminal Equipment DTE connected to the RS232 interface and it is managed by AT commands according to the GSM 07.07 and 07.05 specification and the supported commands are listed in the AT Commands Reference Guide.

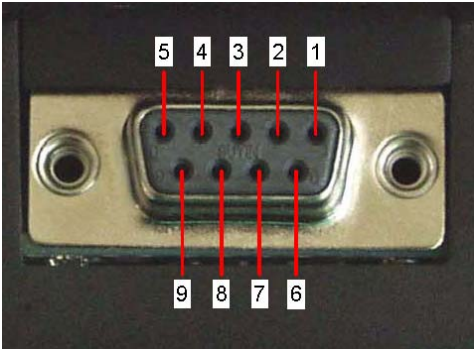

Figure 5: Pin assignment RS-232 (D-Sub 9-pole female)

Pin no.	Signal name	I/O	Function of application
1	DCD	O	Data Carrier Detected
2	RXD	O	Receive Data
3	TXD	I	Transmit Data
4	DTR	I	Data Terminal Ready
5	GND	-	Ground
6	DSR	O	Data Set Ready
7	RTS	I	Request To Send
8	CTS	O	Clear To Send
9	RING	O	Ring Indication

Table 2: D-Sub 9-pole female RS232

Connector type on the terminal is:

- RS-232 through D9-pin female
- Baud rate from 300 to 115.200 bit/s
- Short circuit (to Ground) protection on all outputs.
- Input voltage range: -12V to +12V

## 2.5 GPIO Interface

The GPIO interface provides via 6 pins RJ11 connector the following options:

- 2 analog inputs or 2 GPIO digital, internal jumpers selection.
- 2 open collector outputs or 2 GPIO digital, internal jumpers selection.
- 1 input power and 1 Ground

Pin assignment

- 1 – GND
- 2 – ADC1 or GPIO1
- 3 – ADC2 or GPIO2
- 4 – Open collector 1 or GPIO 3
- 5 - Open collector 2 or GPIO 4
- 6 – Input Power ( 12v )

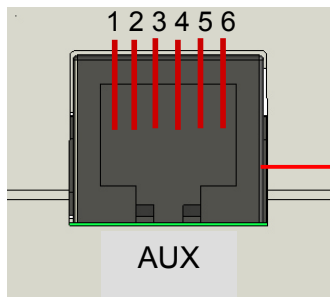

Figure 6: GPIO RJ11 plug (6-pole female)

## 2.6 GPIO Selection

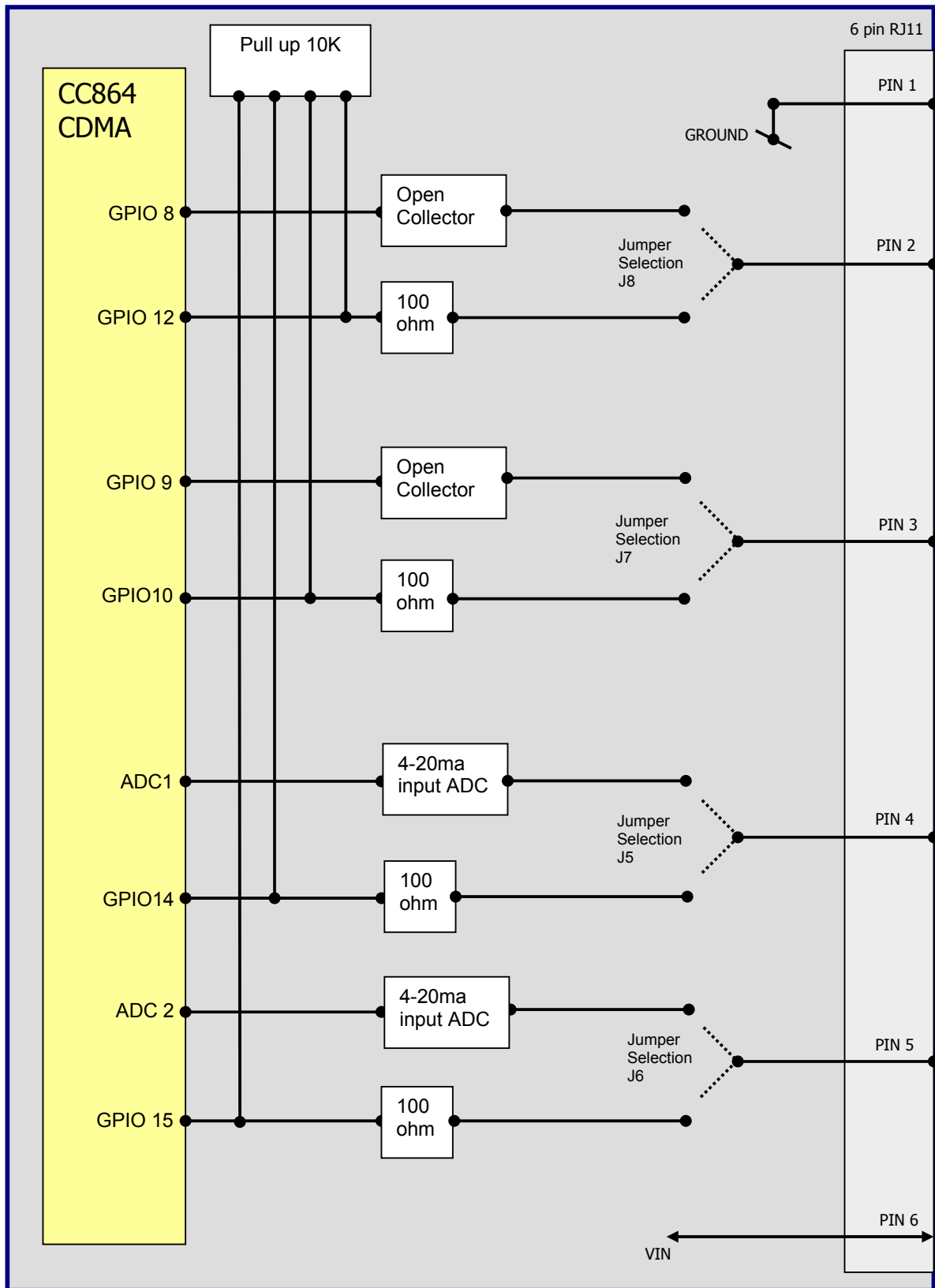

Figure 7: GPIO RJ11 plug setup options

## 2.7 Analog-to Digital Converter (ADC)

The two analog inputs are used for measuring external sensors of 4-20ma. Input parallel 100 ohm resistor convert the 4 - 20ma to 0.4 – 2.0 V to the ADC input.

Note: Only positive voltage can be handled because of the input requirement of ADC.

A/D is 11-bit converter. It is able to read a voltage level in the range of 0÷2 volts applied on the ADC pin input, store and convert it into 11 bit word.

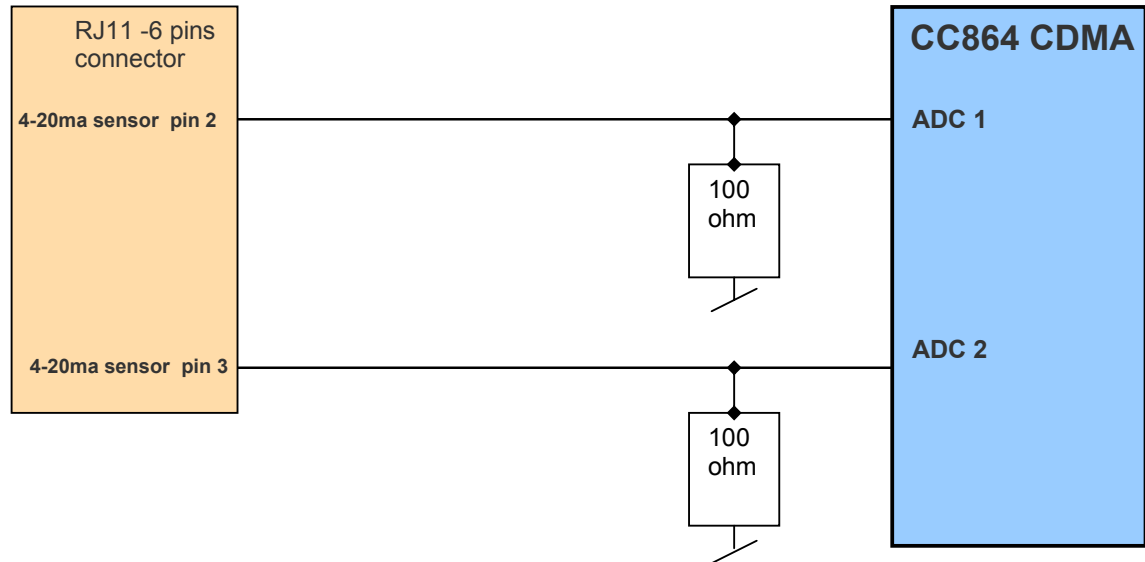

Figure 8: Connections for ADC

## 2.8 Relay

The internal Relay pins 13,14 at the 24 pins interface connector may be used for controlling external circuit devices or applications. The relay parameters:

- Maximum voltage = 30V @ max. 1A.
- The Relay is set to normally open ( R121 install ).

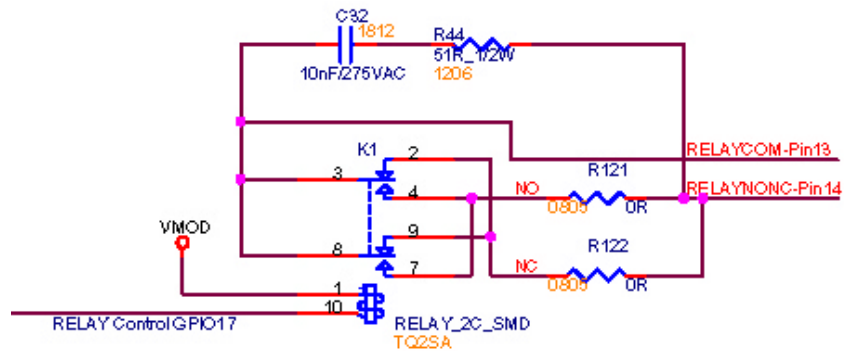

Figure 9: Relay Control

## 2.9 Status LED

**Red LED** displays the network status of the EZ864 CDMA Terminal.

<b>Red LED status</b>	Device Status
permanently on	a call is active
fast interrupt sequence (period 0,5s, Ton 1s)	Net search / Not registered / turning off
slow interrupt sequence (period 0,3s, Ton 3s)	Registered full service
permanently off	device off

Table 3: RED LED Status

**Green LED** displays the operating status of EZ864 CDMA

<b>Green LED status</b>	Device Status
permanently ON	Unit active
fast interrupt sequence (period 1s, Ton 1s)	Error: Net search / Not registered
OFF for 1s and then ON	Unit get phone call
permanently OFF	device off

Table 4: Suggested application for GREEN LED Status

## 4. Mechanical Characteristics

Weight	150g
Dimensions (max) L x W x H	83mm x 64 x 33mm
Temperature range	-20°C to +70°C ambient temperature
Protection class	IP40 Avoid exposing EZ864 Terminal to liquid or moisture
Mechanical vibrations Amplitude	7.5mm at 5-200Hz sinus
Air humidity	5% - 85%
Class of flammability	UL94 HB
Casing material	Aluminum

Table 5: Mechanical characteristic

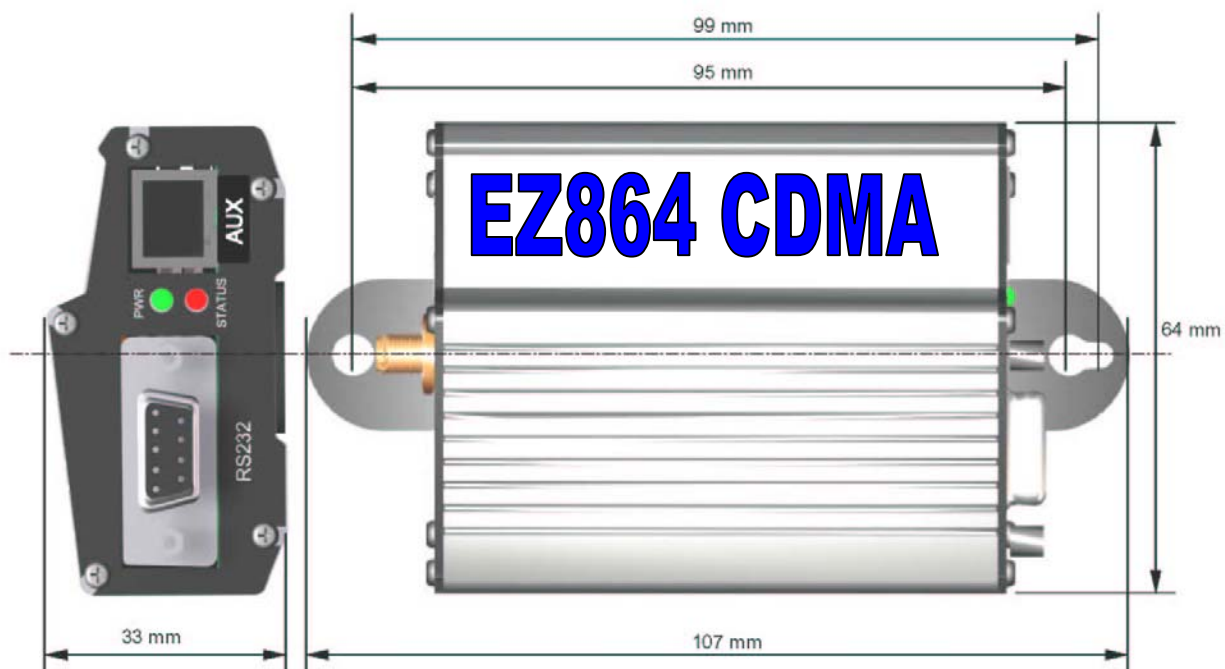

## 5.2 Power Supply

This chapter provides specifications for the power supply which serves the Terminal. The power supply we recommended is 12V 1.2A part number EZ12V1.2A. The type of the receptacle assembled on the EZ864 CDMA Terminal is 4 pin Micro Mate-N-LOK 3mm from MOLEX. Mating headers can be chosen from the MOLEX Micro Mate-N-LOK Series. For latest product information <http://www.molex.com>

## 5.2 GSM antenna

This chapter provides specifications for the GSM antennas which serves the Terminal.

We recommended 4 types of GSM antennas with SMA connector:

900/1800Mhz 2.5dBm 3 meter cable part number EZantenna2.5db3M9001800.

850/1900Mhz 2.5dBm 3 meter cable part number EZantenna2.5db3M8501900.

900/1800/1900Mhz 1dBm 5 cm 90 degree SMA part number EZantenna1db5m90018001900SMA.

900/1800/1900Mhz 1dBm 5 cm for internal assembly part number EZantenna1db3M90018001900int.

# 6. SAFETY RECOMMANDATIONS

### READ CAREFULLY

Be sure the use of this product is allowed in the country and in the environment required. The use of this product may be dangerous and has to be avoided in the following areas:

Where it can interfere with other electronic devices in environments such as hospitals, airports, aircrafts, etc. Where there is risk of explosion such as gasoline stations, oil refineries, etc

It is responsibility of the user to enforce the country regulation and the specific environment

regulation. Do not disassemble the product; any mark of tampering will compromise the warranty

validity. We recommend following the instructions of the hardware user guides for a correct wiring of

the product. The product has to be supplied with a stabilized voltage source and the wiring has to be

conforming to the security and fire prevention regulations. The product has to be handled with care,

avoiding any contact with the pins because electrostatic discharges may damage the product itself.

Same cautions have to be taken for the SIM, checking carefully the instruction for its use. Do not

insert or remove the SIM when the product is in power saving mode. The system integrator is

responsible of the functioning of the final product; therefore, care has to be taken to the external

components of the module, as well as of any project or installation issue, because the risk of

disturbing the GSM network or external devices or having impact on the security. Should there be any

doubt, please refer to the technical documentation and the regulations in force. Every module has to

be equipped with a proper antenna with specific characteristics. The antenna has

to be installed with care in order to avoid any interference with other electronic devices and has to

guarantee a minimum distance from the body (20 cm). In case of this requirement cannot be satisfied,

the system integrator has to assess the final product against the SAR regulation.

The European Community provides some Directives for the electronic equipments introduced on the

market. All the relevant information's are available on the European Community website:

<http://europa.eu.int/comm/enterprise/rtte/dir99-5.htm>

The text of the Directive 99/05 regarding telecommunication equipments is available, while the

applicable Directives (Low Voltage and EMC) are available at:

[http://europa.eu.int/comm/enterprise/electr\\_equipment/index\\_en.htm](http://europa.eu.int/comm/enterprise/electr_equipment/index_en.htm)