

# EzDog V5.1 Product Description

Rev. 1 – 24/01/11



## 1. Overview

Aim of this document is the description of features, functions and interfaces of the EzDog unit. The EzDog is a complete system solution for tracker applications based on Telit GE863-PRO3 modem.

The unit includes Telit cellular GSM engine with ARM 9 and LINUX operating system, GPS modem, 3 Axis accelerometer sensor, CAN bus communication support and MicroSD card.

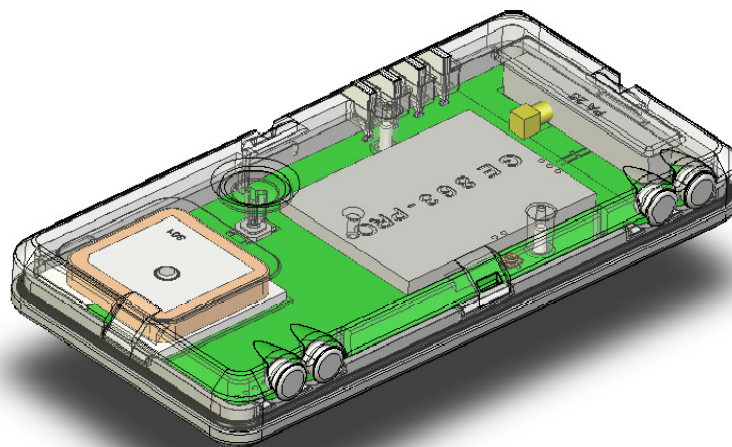
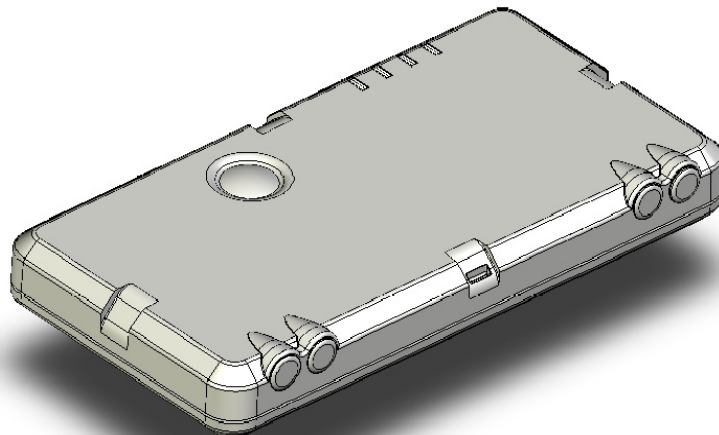

## 2. General Product Description

### 2.1 Mechanical assembly

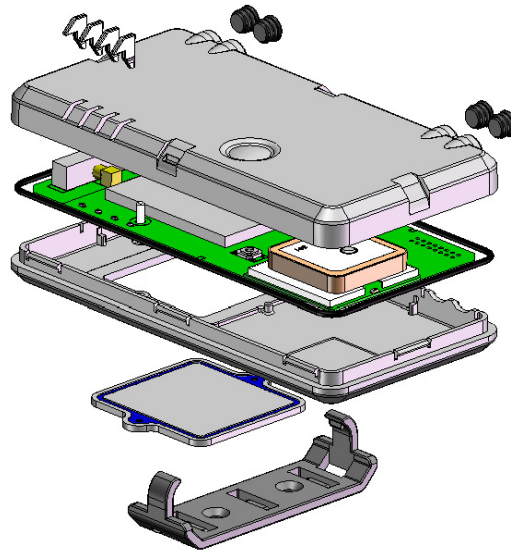

### 2.1 Dimensions

Dimensions: 113mm x 58mm x 14.8mm (without the unit holder)

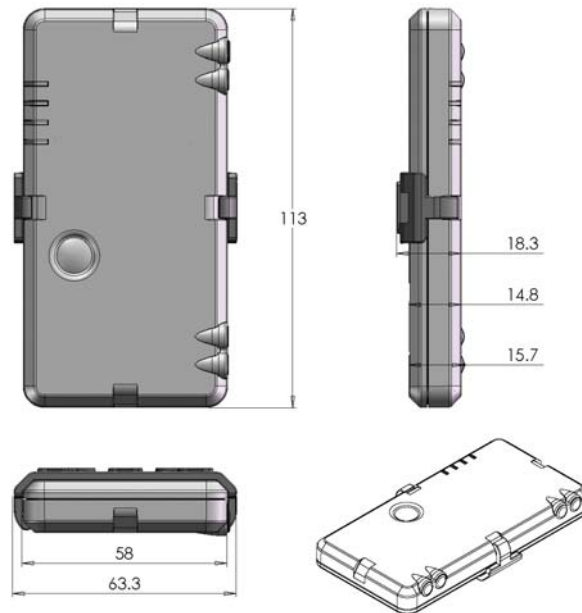

## 2.2 Weight

The weight of the EzDog is 120 grams.

## 2.2 Installation

The EzDog can be installed in two ways:

1. It can be fixed on a suitable surface by two screws through holes on the unit holder
2. On the two edges of the unit there are niches for zip ties

## 2.3 Casing material

The EzDog case made from plastic PC

## 2.4 Environmental requirements

### 2.4.1 Temperature range

	Ambient temperature in plastic enclosure	Note
Operating Temperature Range	-20°C to +55°C	The unit is fully functional in all the temperature range, and it fully meets the ETSI specification
	-30°C to +85°C	The module is fully functional in all the temperature range. Temperatures outside the range -20°C to +55°C, might slightly deviate from ETSI specifications
Storage and Non Operating Temperature Range	-40°C to +85°C	

### 2.4.2 Air humidity range

5% - 85%

### 2.4.3 RoHS compliance

All hardware components are fully compliant with the EU RoHS and WEEE Directives

## 3. Hardware Interface Description

### 3.1. Main Features of the EzDog

Feature	Implementation
Incorporates Telit GE863 PRO module	The Telit module handles all GSM processing for signal and data within the EzDog.
Incorporates ARM 9 Inside GE863 PRO	Power full controller with 128MB Flash 64MB RAM. With LINUX operating system inside
Accelerometer	Freescale MMA8450Q - 3 Axis digital accelerometer, up to 12 bit and 400Hz sample rate
Frequency bands	Quad band: GSM 850/900/1800/1900MHz
Power supply	Single supply voltage 6V to 30V
ADC and GPIO inputs*	<ul style="list-style-type: none"> <li>• 2 open collector outputs, 250ma each</li> <li>• 2 ADC inputs for Analog sensors</li> <li>• 2 Digital inputs for 0 to 30V (use for IGNTION and DOOR detect)</li> <li>• 2 Digital inputs counters</li> </ul>
Low energy support	Unit can work on 5ma consumption
LED interface	4 LEDs placed on the plastic case: <ul style="list-style-type: none"> <li>• 3 LEDs controlled by the ARM processor</li> <li>• 1 LED controlled by the GPS module</li> </ul>
Communication interface	Debug* (Tx, Rx) – For Linux commands RS232* (Tx, Rx) – For serial interface RS485* USB Host** USB Device** CAN bus* - MCP2515 CAN controller
GPS module SIRF star III	Sensitivity -159dBm Tracking, 20 Channels
MicroSD	Micro SD card FAT32 support
Temperature sensor	LM73 – 14 bits temperature sensor
Battery	Internal 460mAh LiPo battery with internal charger

(\*) Only 7 signals can be selected on the unit's cables.

(\*\*) Optional cable

## 3.2. Interface Description

### 3.2.1 Overview

EzDog provides the following connectors for power supply and Interface.  
There are 2 cables, 4 wires and 6 wires:

**Cable 1:**

Pin number	Description
1	input power + 6 to 30V
2	GROUND
3	Option 1
4	Option 2

**Cable 2:**

Pin number	Description
1	Option 3
2	Option 4
3	Option 5
4	Option 6
5	Option 7
6	Digital GROUND

All the optional signals (1-7) will be selected from:

- 2 open collector outputs, 250ma each (1 wire each)
- 2 ADC inputs for Analog sensors (1 wire each)
- 2 Digital inputs for 0 to 30V (1 wire each)
- 2 Digital inputs counters (1 wire each)
- Debug serial interface for Linux commands (2 wires)
- RS232 serial interface (2 wires)
- CAN bus (2 wires)
- RS485 (2 wires)

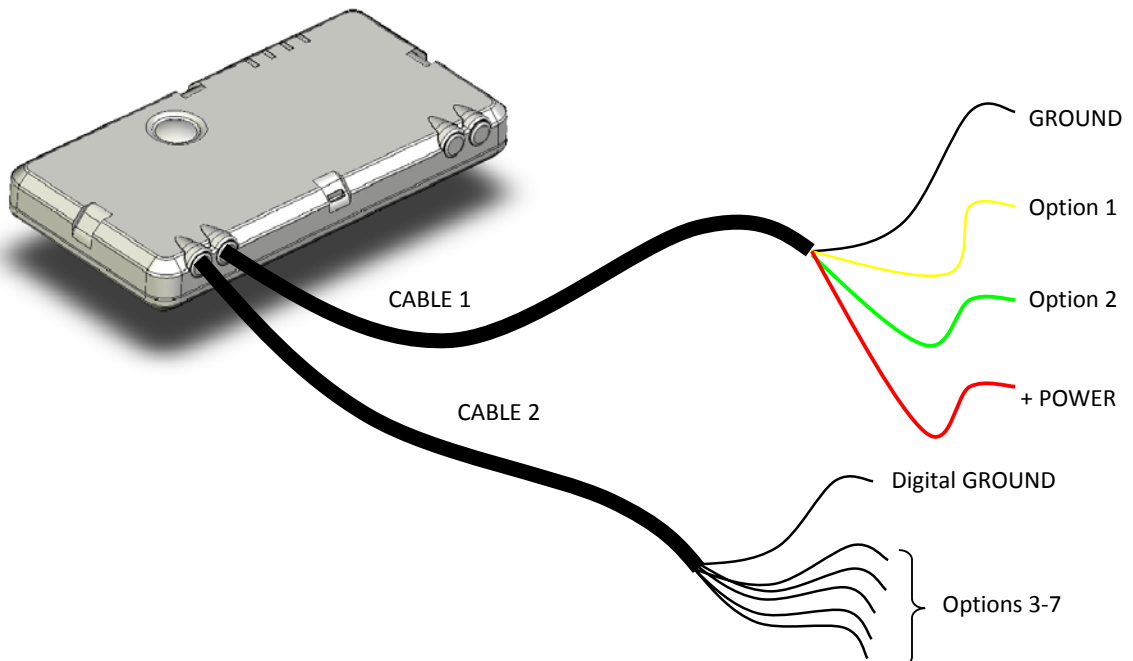

### 3.2.2 Power Supply

The power supply of the EzDog Terminal has to be a single voltage source of POWER 6V-30V capable of providing a peak during an active transmission. The EzDog Terminal is protected from supply voltage reversal. An internal fuse ensures an electrical safety according to EN60950-1. This fuse is not removable. A fast acting fuse 0.8A with melting is necessary to use with the EzDog at a 24V power supply system for vehicles.

#### 3.2.2.1 Supply voltage requirements

The DC power supply must be connected to the POWER input:

- Input voltage range 6 - 30V DC
- Nominal Voltage 12V DC
- Power Supply current rating: max. 2A @12V
- Power Supply ripple: max. 120mV
- Input current in idle mode: 57mA @ 12V
- Input average current in communication mode: 150mA @ 12V

#### 3.2.2.2 Power consumption

The consumption measured with 12V input without RS232 load.

- ARM, Modem to GSM network, GPS active and CAN bus:

ARM	Modem	GPS	CAN bus	Current
Fully functional	Registered	Navigate mode	Active	~57mA
Fully functional	Off	Navigate mode	Active	~48mA
Fully functional	Off	Off	Active	~35mA
Standby mode	Off	Off	Active	~21mA
suspend to RAM	Off	Off	Active	~8.7mA
Fully functional	Registered	Navigate mode	Sleep	~54mA
Fully functional	Off	Navigate mode	Sleep	~44mA
Fully functional	Off	Off	Sleep	~30mA
Standby mode	Off	Off	Sleep	~17.5mA
suspend to RAM	Off	Off	Sleep	~5mA

## 4. EzDog main Block Diagram

Figure below shows a block diagram of a sample configuration that incorporates the EzDog.

